



## SUMMARY

### **WOOD EXPERTISE**

Complete control of oak supplies	p 06/07
A strict selection by grain	p 08/09
A stave mill in the heart of a protected site	p 10/11

### **RESEARCH AND DEVELOPMENT**

OakScan®, the first scientific innovation applied to the selection of wood	p 14/19
--	---------

### **TOAST: A PRECISION ART**

Qualified, reproducible toasts	p 22/23
Toasts for red wines	p 24/25
Toasts for white wines	p 26/27
Toasts for spirits	p 27
Toasts for American oak	p 28/29

### **OUR COLLECTION**

Extra Fine X-Blend, state-of-the-art selection by grain	p 32/33
Super Fine Blend, the perfect harmony between wood and wine	p 34/35
Omega, excellence by nature	p 36/37
The Bordeaux 225 litres barrel	p 38/39
The Burgundy 228 litres barrel	p 40/41
Large barrels	p 42/43
Spirit barrels	p 44/45
Innovation and custom-made products, Radoux's DNA	p 46/47
Tables of recommendations	p 49/65
Advice before use	p 66
Options	p 67

### **VATS AND CASKS**

Radoux, Cask maker since 1947	p 70/73
Accompanying your project	p 74/79

### **OUR COMMITMENT**

Sustainable development	p 82/83
Quality references	p 84
Our team	p 85



## 70 years of history

**Founded in 1947**, Radoux has succeeded in taking its place among the top barrel makers over the course of several decades.

Thanks to its expertise in the knowledge of oak and investment in Research and Development, it has gained the trust of the greatest wine estates the world over.

Situated in Jonzac, in the heart of Cognac, and specialized since inception in the manufacture of barrels for spirits, Radoux is also a reference in the spirits market.

Radoux has a team of professional coopers, including Meilleurs Ouvriers de France who pass on their knowledge and supervise every stage of the manufacture of the barrels. Radoux combines traditional craftsmanship with technological skills, thus guaranteeing the quality, homogeneity and consistency of its barrels.



From selecting the wood to consulting with winemakers, Radoux preserves the tradition of French cooperages.

Recognized worldwide as a top-quality cooperage, Radoux barrels can be found in over forty countries.

Bringing together two brands of international importance: Radoux and Pronektar - Radoux is part of the **TFF Group**, undisputed world leader for barrel making for aging wines and spirits, as well as wood products for oenology.





# Wood expertise



# Complete control of oak supplies

Of the many existing oak species, only three are traditionally used in barrel making :

**Sessile oak (Quercus petraea)** which grows more slowly and has a tight grain particularly suited to the aging of wines.

**Pedunculate oak (Quercus robur)** which grows more quickly and produces a wider grain, used more commonly for aging spirits.

**American oak, or « white oak » (Quercus alba)** which grows more rapidly than French oak and has more aromatic, rather than tannic, qualities.

**Radoux has its own team of wood purchasers. We source our wood from the ONF and sometimes from private producers.**

Our buyers select the best oak specimens from the most prestigious forests in the Centre and North East of France and worldwide. This is an essential stage which relies on a perfect understanding of the raw material, human expertise, and scientific research.

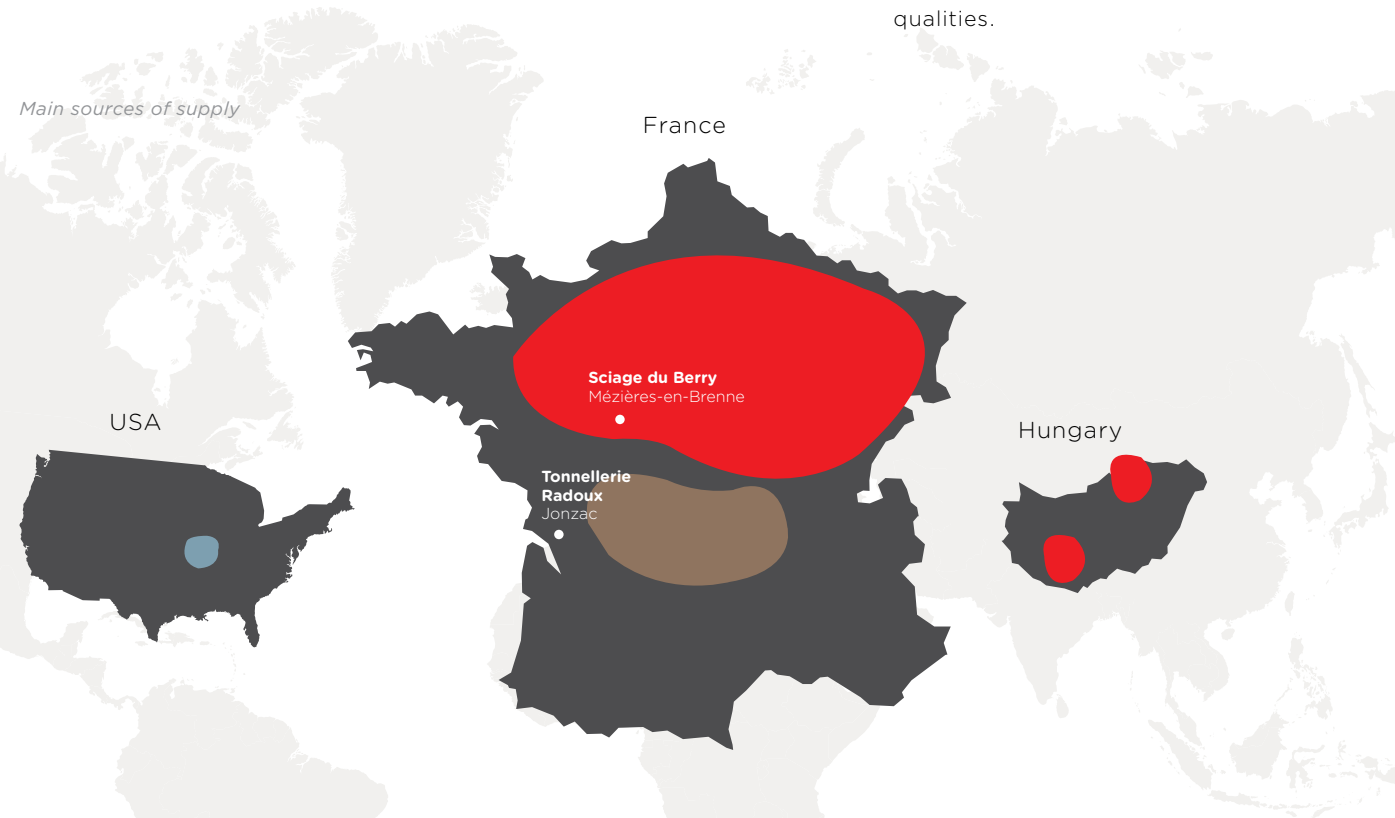

Thanks to its dedicated purchasing department and integrated saw mill, Radoux is able to fully control and secure its supplies.

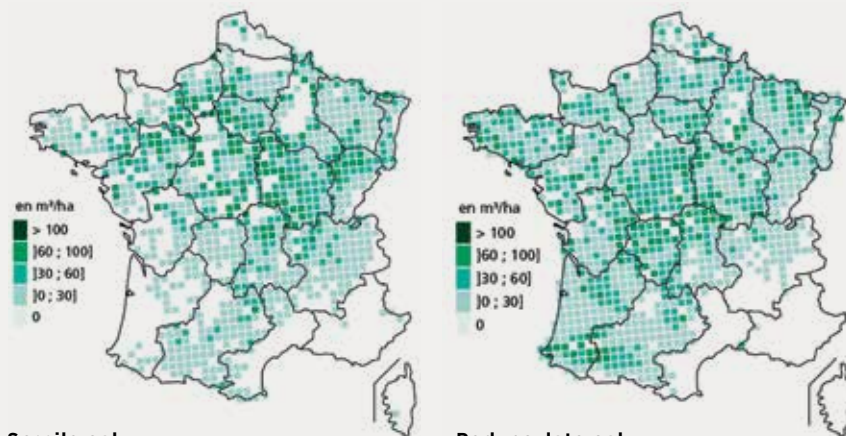

**Sessile oak**  
**Quercus petraea Liebl.**

Average volume per hectare

**Pedunculate oak**  
**Quercus robur L.**

**The notion of origin does not guarantee the selection of the species**

Sourcing by origin is traditionally the first step in selecting the wood. Sessile and pedunculate species can be found in most of the supply areas in France.

However, neither the geographical region, nor the forest alone can provide a guarantee of quality.

This is why Radoux has added two additional criteria : grain size and our proprietary OakScan® technology



# A strict selection by grain

## EXTRA TIGHT GRAIN :

Used to make our Super Fine **Blend** and Extra Fine **X-Blend** barrels meant for lengthy periods of aging.

## TIGHT GRAIN :

Radoux's reference and heart of the range, the Tight Grain Selection is meant for traditional aging.

## ALLIANCE/MIXED GRAIN : (MEDIUM & TIGHT GRAIN )

A blend of tight and medium grain, this selection is meant for shorter aging, combining moderate aromatic richness with structure on the palate.

## MEDIUM GRAIN :

Usually used for shorter aging periods, this selection is characterized by a lower, but more rapid aromatic contribution.

## WIDE GRAIN :

Mainly used for aging spirits, this category of grain is characteristic of Limousin oak.

**The grain, or growth ring of the wood is inseparable from the quality of French oak.**

The grain corresponds to the average width of the growth ring of the tree : the smaller it is, the tighter the grain. Each piece of timber is therefore selected according to its grain and is assigned a specific quality corresponding to a particular product within the range.

Extreme tightness of the grain will give wine a great aromatic complexity, a delicate structure, and fine and soft tannins, which will be released gradually during the aging process. As a result of research which highlighted the prominence of grain over origin, Radoux was quick to integrate this into the selection of its wood, and created, back in the 1990s, the first barrel to be made from a blend of forest origin sorted by extra-tight grain oak : the Super Fine Blend.



### IMPORTANCE OF GRAIN IN CONTRIBUTION OF AROMAS

Analyses show that levels of lactones drop from the tightest to the widest grain.

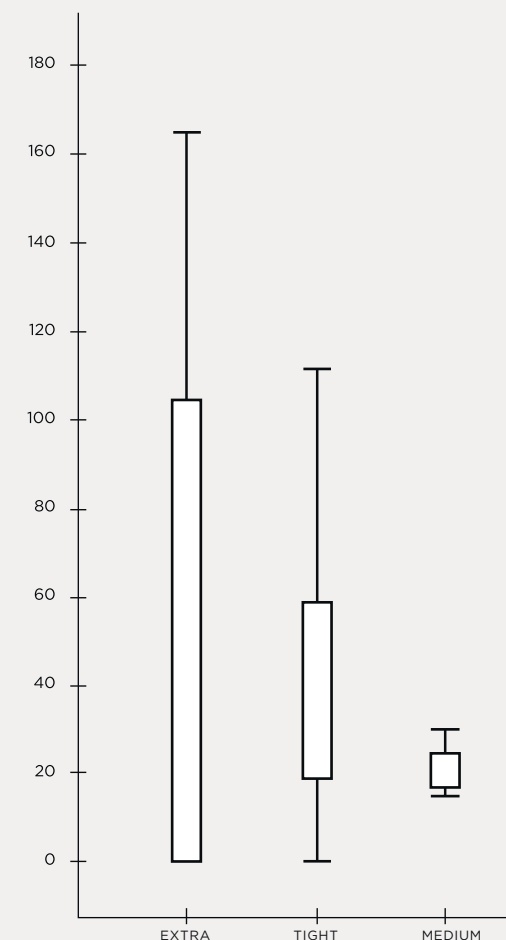

LEVEL OF GAMA-OCTA LACTONES CIS+TRANS ACCORDING TO GRAIN

Sources internes (2016 / R&D Radoux)

### LEVEL OF TANNINS ACCORDING TO GRAIN

Analysis of samples graded according to grain, show tannin levels (evaluated by their polyphenolic index) increase from the tightest to the widest grain.

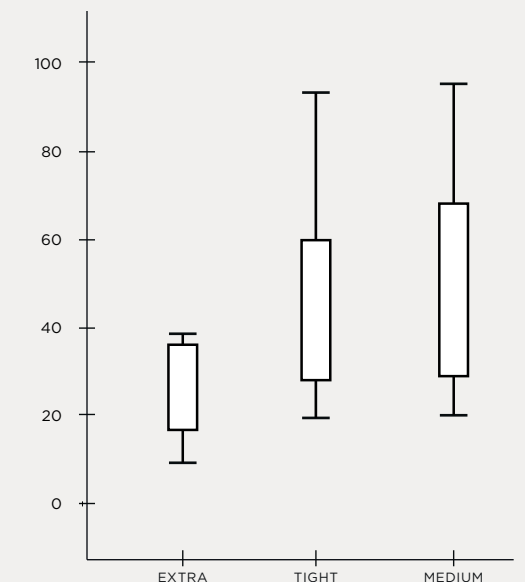

LEVEL OF TANNINS (POLYPHENOLIC INDEX) ACCORDING TO GRAIN

Sources internes (Juin 2008 / R&D Radoux)

**OUTCOME: grain sorting tends towards better control of aromatic and polyphenolic levels.**



## A stave mill in the heart of a protected site



**In the heart of the Brenne Regional National Park and a site classified Natura 2000\*, our stave mill is spread over a vast estate of several hectares.**

This natural area, where the quality of the air and water is preserved, provides **exceptional environmental conditions** for perfect wood seasoning.

Because of its location in Mézières-en-Brenne - equal distance from the main forests - the carbon footprint associated with transport of the timber is limited.

In this workshop logs are split, not sawn, to respect the grain of the wood and to obtain rough staves. Wood for oenology, under our brand name **Pronektar**, is also produced in Mézières-en-Brenne.



**An ultra-modern production facility**, our stave mill respects strict rules pertaining to **traceability, control and safety**, which enables us to guarantee an optimum quality for our wood.

\* Natura 2000 brings together natural or semi-natural sites within the European Union which have great heritage significance because of their fauna and flora.



### Maturation, a key stage

Radoux uses its own method to stack the rough staves to ensure they are well ventilated and watered for the best possible maturation.

They are left outside exposed to the sun, wind and rain for a minimum maturation period of **two years**, and up to over **three years**.

This 100% natural drying process in the open air helps reduce the level of tannins in the wood. It also aims to eliminate certain negative odorous compounds and to obtain a moisture content of between 14 and 17%.

By respecting the maturation time, the aromatic and phenolic compounds are able to gradually transform and when subjected to a controlled toast, will release the characteristics which will contribute to the quality of the wines or spirits.





# Research and development



Radoux pursues its ambition of controlling its raw material to ensure it is an essential partner in precision oenology.



At the beginning of the new millennium, Radoux set up its Research and Development department to improve its knowledge of the raw material and further its scientific study of the production process.

**The team, which is made up of engineers and oenologists, works in close cooperation with numerous organisations:** INRA, IRSTEA, l'Institut Supérieur de la Vigne et du Vin (ISVV)... It also has strong support from partnerships with foreign universities (South Africa, Spain, USA...) and takes part in various conferences (ASEV, MacroWine, OIV...).

By organizing many trial programs, from the selection of the oak to the sensory analysis of finished wines, the team has succeeded in gathering extremely precise information which enables them to offer a range of qualified and reproducible toasts.



At the end of the 1990s, Radoux introduced new criteria into its process with regard to selecting wood: selection by grain. This, together with the research carried out on the control of raw material, led to the perfecting of the Oakscan® process.

### Instantaneous measurement of tannins in wood

Tannins have a major impact on the organoleptic properties of the wines or spirits they enrich. They change the sensory profile, the tannic structure, the colour, and have a protective role with regard to oxidative breakdown.

Until now, only chemical measurements carried out in a laboratory enabled us to measure ellagitannins. These measurements could only be made by taking random samples from batches of rough staves and took a long time to obtain.

In 2008, after several years of research, Radoux's R&D department launched the world's first process to instantly measure the quantity of polyphenols contained in staves: **OakScan®**.



## OakScan®, the first scientific innovation applied to the selection of wood.



## The process

**OakScan®** is a system of rapid analysis, stave by stave, based on Near Infrared Spectrometry. Each stave entering into production is scanned and marked with a letter (« F » on the particular batch in the photo to the right).

This letter indicates which category of tannic potential it belongs to.

It helps the coopers sort the staves more easily and make barrels with specific polyphenolic indexes (PI).

This index estimates that the polyphenolic content of the wood is between 0 and 100.

After ten years of using the system and over **10 million analyses**, **Radoux now has the largest database in the world on the chemical composition of French oak.**



### A unique database on the chemical composition of wood.

Radoux's R&D team regularly carry out trials to highlight the impact of **OakScan® selections on the organoleptic properties of wine.**

These tests are executed on a large scale in cooperation with many oenological institutes, including the ISVV of Bordeaux, on wines coming from the finest wine regions in the world.

Over three hundred trials of **OakScan®** selections have been performed since 2008. Each time, the trials have proved their value in the world's finest vineyards (France, USA, Spain, Italy, Chile, Australia, China..) and on different grape varieties (Chardonnay, Sauvignon Blanc, Merlot, Tempranillo, Syrah, Cabernet Sauvignon, Pinot Noir...).

## The three pillars of oak selection

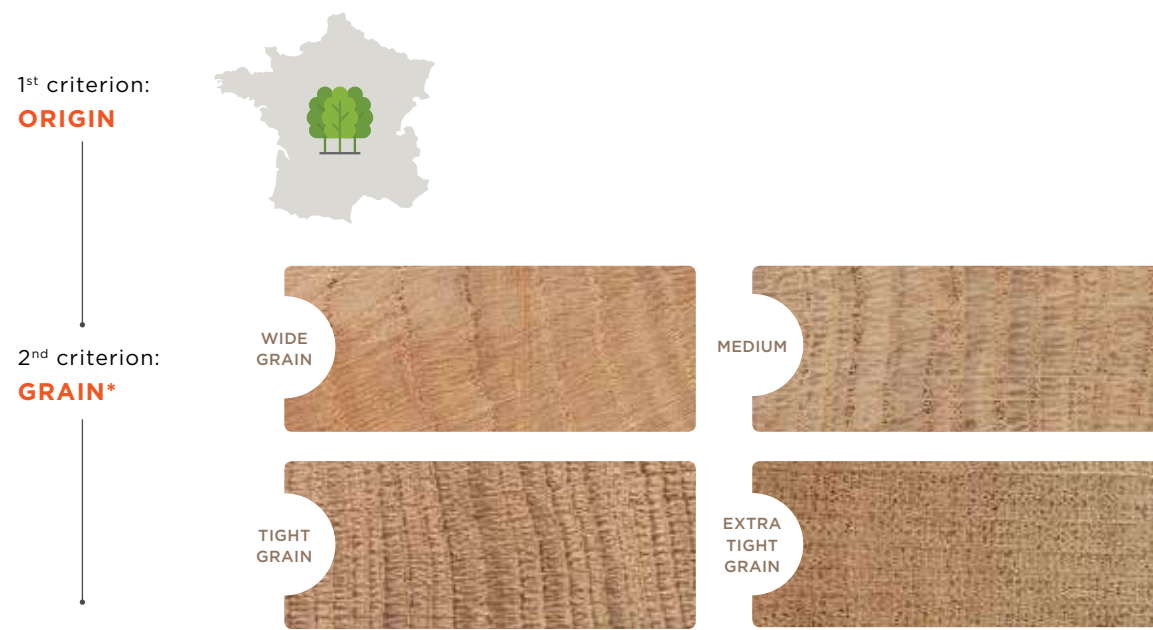

### 3rd criterion: OAKSCAN®

#### Example of the natural distribution of tannins in two batches of wood

Each dot represents a barrel made of approximately thirty staves which have not been sorted.

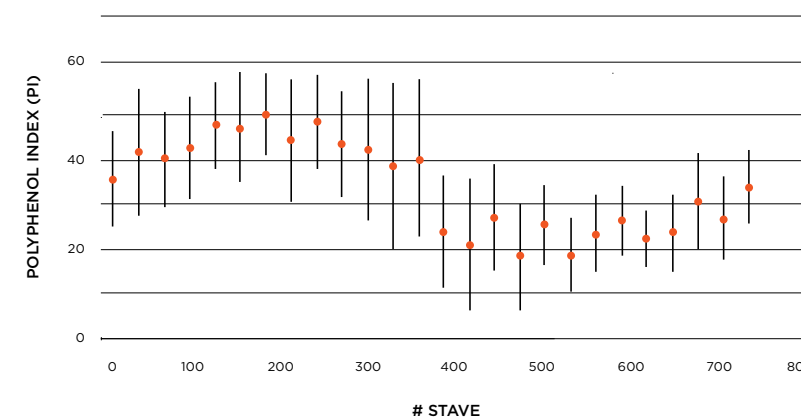

#### Example of a selection made from these two same batches

Each dot represents a barrel made from a batch of approximately thirty staves sorted with the help of **OakScan®**.

- Oakscan 60
- Oakscan 40
- Oakscan 20

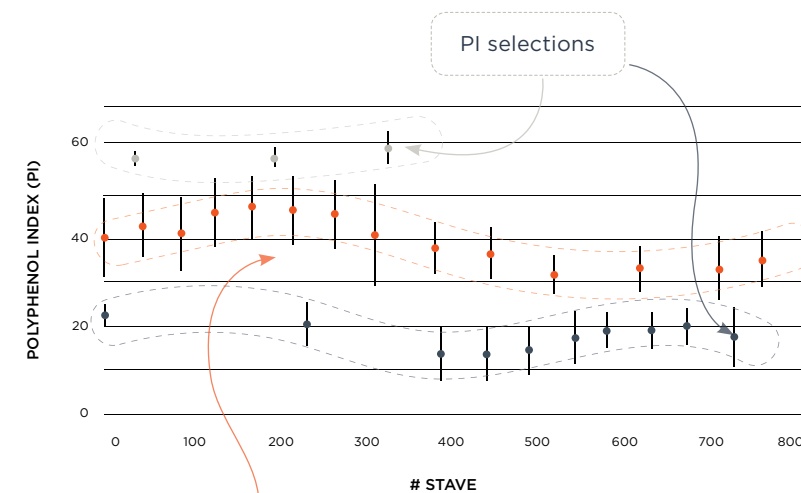

A homogeneous heart of the range

\* non-contractual photos



## OakScan® : a tool in the service of precision oenology

Every stave used in our French and European oak barrels is analysed by OakScan®. Therefore these barrels have a homogenous tannin content.

In addition to traditional selections, Radoux OakScan® helps improve the homogeneity and reproducibility of the results obtained after aging, thus achieving more precise vinification.

- Radoux OakScan® completes the traditional methods of wood selection (origin, grain).
- Radoux OakScan® helps ensure with precision that the barrels made have a homogeneous polyphenol content.
- Radoux OakScan® optimises the suitability of the wood in relation to the type of wine you are seeking to achieve.

### Distribution of main products of the range according to their polyphenolic index OakScan® (PI)

#### Specifics RED

		Polyphenolic Index Oakscan®
French oak	225/228L	
	SUPER FINE BLEND EXTRA FINE X-BLEND	35 <sup>+/-5</sup>
	OMEGA	30 <sup>+/-7</sup>
	TIGHT GRAIN	40 <sup>+/-7</sup>
	TIGHT GRAIN OAKSCAN 20	20 <sup>+/-4</sup>
	ALLIANCE/MIXED (MEDIUM AND TIGHT GRAIN)	40 <sup>+/-10</sup>
	MEDIUM GRAIN	50 <sup>+/-10</sup>
	300L	45 <sup>+/-10</sup>
European oak	225/228L	28 <sup>+/-7</sup>
	300L	28 <sup>+/-7</sup>
	400/500L	28 <sup>+/-7</sup>

#### Specifics WHITE

		Polyphenolic Index Oakscan®
French oak	225/228L	
	SUPER FINE BLEND EXTRA FINE X-BLEND	35 <sup>+/-5</sup>
	OMEGA	30 <sup>+/-7</sup>
	TIGHT GRAIN	40 <sup>+/-7</sup>
	ALLIANCE/MIXED (MEDIUM AND TIGHT GRAIN) OAKSCAN 30	30 <sup>+/-7</sup>
	ALLIANCE/MIXED (MEDIUM AND TIGHT GRAIN) OAKSCAN 50	50 <sup>+/-7</sup>
	MEDIUM GRAIN	50 <sup>+/-10</sup>
	300L	45 <sup>+/-10</sup>
	400L / 500L	45 <sup>+/-10</sup>

#### Specifics SPIRITS

		Polyphenolic Index Oakscan®
French oak	350/400L	
	TIGHT GRAIN	40 <sup>+/-10</sup>
	WIDE GRAIN	60 <sup>+/-10</sup>







Toast :  
a precision  
art



## Qualified, reproducible toasts

From selecting the wood to consulting with wine-makers, Radoux has preserved the French tradition since 1947.

At Radoux cooperage, the skills and savoir-faire of our coopers is essential and irreplaceable. Its teams are made up of many professional coopers and **Meilleurs Ouvriers de France**.

Radoux combines the hands on, manual skills of its craftsmen, (visual control of the staves, positioning of heads, toasting...) with top quality technology guaranteeing quality, homogeneity and regularity of its barrels.

**The control of the toasting process is a fundamental part of the organoleptic expression of the wood.**

The toasting process helps generate the main aromas which can enhance wines and spirits and significantly modify the quality of the sensations on the palate (texture, volume, sweetness).

Our R&D department has developed a wide range of toasts for wine as well as a specific range for spirits.

Our traditional toasts have been studied so that depending on the origin of the wood, its grain, the grape variety and length of aging, they bring either a discreet or more marked tannic content and aromatic flavor.

Everything is done to control the temperature inside the barrels, thus enabling us to offer qualified and reproducible toasts which meet with precise oenological objectives.

## Radoux toasts

The pre-toast is the first stage of Radoux's toasting process. Gradual heating helps prepare the staves for bending, tightening and shaping into barrels. This stage is carried out in the traditional way, using a wood brazier and water.

The second stage involves a slow, prolonged heating of the barrel. This helps to fix the final shape of the barrel and establish its organoleptic profile. It is crucial that this stage be fully controlled as it allows for a harmonious development of aromas and preserves good structure.

The heads represent around 30% of the surface exchange between the wood and wine. A unique toasting process is offered as an option to strengthen the aromatic complexity and optimize the homogeneity of the toasting of the barrels.

Each barrel entering the toasting process undertakes a strict control of the length of toast and its intensity.







Example of Pure to Medium + toasts

# Toasts for red wines

## PURE

### Respect of fruit and character

Pure toast is meant for wine-makers who are seeking the purity of the wine, the respect of the fruit and the terroir. It is carried out at low temperatures over a long period. This gentle, deep toast helps preserve the original aromas of the wine. Its long, delicate interaction with the wood's tannins generates volume, finesse and length. It gives remarkable texture in the mouth.

The Pure toast, associated with tight grain and Oakscan wood selection, respects the raw material and enhances the wine, giving expression to the fruit while respecting its origin.

## REVELATION

### Harmony and softness

Revelation toast is moderate, aimed at generating soft aromas (creamy, vanilla). More intense than the Pure toast, it is suited to wines with good structure, to which it will add more volume, while respecting the profile of the fruit.

## EVOLUTION MEDIUM

### Roundness and elegance

Evolution medium toast favors the fruit and the roundness of the tannins. This toast is carried out in two stages and results in balanced aromas, round tannins in the mouth, and additional sweetness.

## CLASSIQUE MEDIUM

### Intensity and structure

Classique medium toast is meant for long aging periods and wines with good aging potential. Well rounded aromas, sweetness and volume are developed thanks to this slow, prolonged toast.

## EVOLUTION MEDIUM +

### Roundness and complexity

Evolution medium+ combines a long and intense toast in the initial phase with a more intense « boucinage », resulting in intense tasty aromas (brioche, caramel..) with roundness and sweetness on the palate.

## CLASSIQUE MEDIUM +

### Richness and volume

This is an intense toast, meant for long aging periods. It stands out by leaving remarkably long-lasting aromas on the palate.

## HEAVY

### Aromatic strength

This toast brings woody, toasty and chocolate notes, a rich aromatic palette combined with power on the palate.

## INTEGRATION

### Mellowness and finesse

Integration toast was created to satisfy specific requirements of delicate wine varieties which are sensitive to tannins. Some toasted notes on the nose, with an excellent integration of tannins in the mouth in the first months of aging.

	NOSE				MOUTH			
	FRUITY/FLORAL	VANILLA	SPICES	TOASTED	FRUITY	SWEETNESS	VOLUME	PERSISTENCE
<b>PURE</b>	••••	•			••••	••	••••	••••
<b>REVELATION</b>	•••	••	•	•	•••	•••	••••	••
<b>EVOLUTION MEDIUM</b>	••	••	••	••	••	••••	•••	••
<b>CLASSIQUE MEDIUM</b>	••	•••	•••	•••	••	•••	•••	••
<b>EVOLUTION MEDIUM PLUS</b>	••	•••	••	•••	•	••••	••	•••
<b>CLASSIQUE MEDIUM PLUS</b>	•	••	••••	••••	•	••	••	•••
<b>HEAVY</b>		••	••••	•••••		•	•	•••
<b>INTEGRATION</b>	••		•••	•••	••	••	••	••



# Toasts for white wines

## PURE

### Freshness and purity of the fruit

This toast is for winemakers who are seeking respect of the grape variety and freshness for their white wine. It can be adapted to Chardonnay type wines, to maintain their tension, or to Sauvignon Blanc wines to respect their freshness. It has very little impact on aromas, but good intensity mid-palate and an overall persistence.

## REVELATION

### Sweetness and softness

Slightly more aromatic than the Pure toast, its aim is to soften the white wines, with light notes of vanilla. It is suited to rich, concentrated white varieties.

## EVOLUTION

### Roundness and volume

Evolution gives priority to the roundness of tannins and is meant for wines to be drunk young. Moderate contribution of aromas, with a lot of sweetness on the palate.

## CLASSIQUE

### Power

Classique is meant for rather long aging and for white wines with long aging potential (sweet wines). A complex aromatic contribution, it can also reinforce the volume and persistence on the palate.

## INTEGRATION

### Delicate structure

Very moderate contribution of structure, it can reveal toasted notes on the nose. It has a delicate tannic impact and is suited to varieties which take on the oak rapidly.

	NOSE				MOUTH			
	FRUITY / FLORAL	VANILLA	SPICES	TOASTED	FRUITY	SWEETNESS	FRESHNESS	PERSISTENCE
PURE	••••	•			••••	••	••••	••••
REVELATION	•••	••	•	•	•••	••	••	••
EVOLUTION	•••	••	••	••	••	•••	•••	•••
CLASSIQUE	••	•••	•••	•••	••	•••	•	••
INTEGRATION	••		••	••	••	••	•	••

# Toasts for spirits



It is while it is aging in barrels that a spirit gains its color and aromas.

The **Spirit Heavy** toast rapidly brings an amber color, aromas of mocha, licorice, roasted almonds, and subtle notes of vanilla.

The **Spirit Medium** and **Medium Plus** toasts give less color and more complex vanilla aromas which will express themselves more over time. They are suited to a longer aging period.

**Spirit Pure** toast brings even less color and enriches the spirits with delicate oak notes, spices and lactones.

	NOSE				COLOR
	FRUITY / FLORAL	VANILLA	SPICES	TOASTED	FROM PALE YELLOW TO INTENSE BROWN
PURE (SPIRIT)	••••	••	•	•	•
MEDIUM (SPIRIT)	•••	•••	••	••	••
MEDIUM PLUS (SPIRIT)	••	••••	••••	•••	•••
HEAVY (SPIRIT)	••	••	•••	••••	••••

	MOUTH				
	INTENSITY	ROUNDNESS	SWEETNESS	MELLOWNESS	PERSISTENCE
PURE (SPIRIT)	••	••	•••	•••	•
MEDIUM (SPIRIT)	••	•••	••	•••	••
MEDIUM PLUS (SPIRIT)	•••	••••	•••	••••	•••
HEAVY (SPIRIT)	••••	••	••	••	••••



# Toasts for American oak

Temperature and length of toast have been developed to reduce the "whisky lactones" typical of American oak. This results in a barrel of great aromatic complexity, with more spicy, balsamic notes, the American character being present in a subtler way. These toasts are generally suited to all types of aging.



### Softness and balance

This is suited to both white and red wines. Its aromatic contribution is marked by soft notes such as coconut and vanilla which make the fruity profile more complex.



### Aromatic intensity and complexity

This toast is more complex, bringing more intense, spicy, toasted, caramel notes and a greater persistence on the palate. It is recommended for the aging of red wines and also for white wines.



**With our extensive experience of sourcing American oak, we select our white American oak (Quercus Alba) from the finest forests.**

In the region of Missouri, the white American oak is rich in lactones, low in tannin content, and contributes notes of vanilla, coconut, and sweetness. Our barrels offer a beautiful aromatic complexity of vanilla, caramel, chocolate, spices, and smoky notes.

After strict selection, our wood is aged and milled by our exclusive partner in Missouri. During maturation, which lasts over two years, rough staves are exposed to the rain, wind and sun, seasoning over many months. This is an essential stage which contributes finesse and aromatic complexity.

The fact that we continuously get our oak from the same source enables us to guarantee a consistent aromatic profile of our barrels from one year to the next.

	NOSE				MOUTH			
	SPICES	VANILLA	FRESH WOOD / COCONUT	GRILLED / TOASTY	FRUITY	SWEETNESS	VOLUME	PERSISTENCE
CLASSIQUE MEDIUM	••	••	••••	••	••	••••	••	•••
CLASSIQUE MEDIUM PLUS	•••	•••	•••	•••	•	••••	•	••••



# Our collection





## Extra Fine X-Blend, state-of-the-art selection by grain

**Radoux was a pioneer when creating its BLEND range, introducing the barrel into the world of luxury at the beginning of the 1990s. Extra Fine X-Blend and Super Fine Blend meet with the highest oenological standards and are the result of an exceptional selection of wood and the unique skills of our Master Coopers.**

Result of a demand for perfection taken to the extreme, Extra Fine X-Blend is the ultra-premium barrel for the best wines in the world. It is produced in very limited quantities by a dedicated team made up of our Meilleurs Ouvriers de France.

Extra Fine X-Blend barrels are subject to an unequalled standard of quality and are made from a strict selection of exceptional wood from the finest French oak trees.

With pin-point precision, each stave is individually inspected with care before being selected. The extreme tightness of the grain guarantees a great aromatic complexity. This challenge leaves no room for compromise and every year, only one to two hundred numbered barrels come out of the Radoux workshop.

The finish of the Extra Fine X-Blend barrel is the focus of attention throughout the production process and is, in one word: exceptional. Each stave is scraped by hand and a glass bung gives the final touch of elegance to this barrel. The toast of each barrel is defined with great care by the Cooperage's Sales Manager/Oenologist in consultation with the customer. It is then monitored by the Heads of Research & Development and Quality to ensure everything is done to perfection. An individual certificate of authenticity is issued upon delivery of each barrel and after sales service is guaranteed throughout the life of the Extra Fine X-Blend barrel.

**This exceptional barrel will bestow its richness, complexity and finesse over long periods of aging.**



*Extra fine  
Blend*

BARREL AVAILABLE IN 225 LITRES  
(TRANSPORT OR CHATEAU FINISH)  
.....  
FRENCH OAK  
EXTRA TIGHT GRAIN, PIN-POINT PRECISION



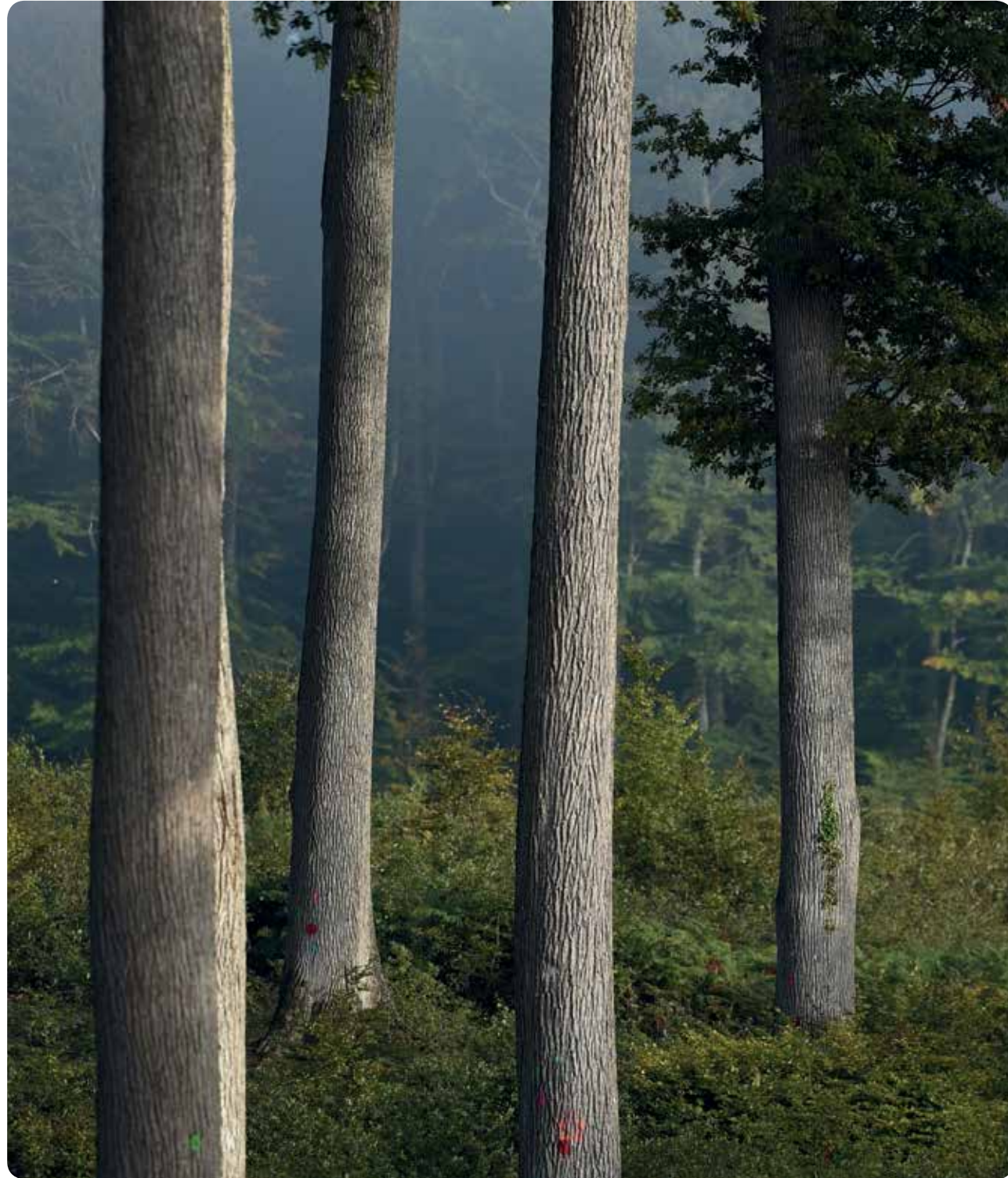

## Super Fine Blend, the perfect harmony between wood and wine

**It is an ideal of perfection which led to the creation of the Super Fine Blend barrel. A subtle blend of the origin of the wood and the tightness of the grain, this barrel has been satisfying the most demanding winemakers' requirements for many years.**

The wood we select is rare and is subject to a specific purchasing policy in the finest forests.

Super Fine Blend is therefore produced in limited quantities, depending on the raw material available. This is also what makes it a very sought-after barrel, singled out by the most prestigious wine estates all over the world.

The tightness of its grain gives the wine maximum aromatic complexity, released gradually during aging, giving a delicate structure with fine, soft tannins. Its very high aromatic potential, with gentle extraction, represents a real investment in quality for winemakers. Super Fine Blend is recommended for long aging periods and can show its worth over several winemaking cycles.

**Super Fine Blend is the most widely distributed premium barrel in the world today.**



*Super Fine Blend*

RANGE AVAILABLE  
IN BORDEAUX 225 LITRES  
AND BURGUNDY 228 LITRES

.....  
FRENCH OAK  
SUPER TIGHT GRAIN <1,5MM





# Omega, excellence by nature

Radoux's new **Omega** barrel is the result of years researching wood, toast and its interaction with wine. It combines all the skills of Radoux's research and production teams with the support of wine experts, renowned consultants, technical directors and international winemakers.

**Great care in the selection of raw material and natural maturation for over three years.**

The wood comes from a subtle blend of oak from the most prestigious French forests. The rough staves dry naturally in the open air for three years and only tight grain staves are selected.

Omega benefits from Radoux's technological innovation OakScan®, which enables the staves to be instantaneously selected according to their polyphenolic index. This process enables us to fine-tune the selection of wood and favour the choice of moderate polyphenolic indices so as to obtain a perfect balance of the potential of the wood (a tannin and lactone content that is neither too high nor too low). Thanks to the combination of OakScan® and wood maturation of over three years, Radoux is able to guarantee a homogeneous level of ellagitannins and wood that is perfectly suited to the oenological objectives.

### Pure : a specially adapted toast

Radoux has developed a specific toast for the **Omega** barrel to promote the bond and integration of wood and grape tannins. Thanks to a thermal action on tannins in matured and seasoned wood, a gentle and long heating process preserves the sweetness of the wood while allowing the wine to acquire volume and texture. In this way, the quality of the raw material is fully respected and the wine is enhanced.

### Respect of the fruit and character

Tasting reveals that the **Omega** barrel gives emphasis to the fruit, with a balance between roundness, volume, tension and length on the palate. The tannins are soft, expressing freshness, elegance and finesse. The complexity of the aromas highlights the expression of the fruit, while respecting its origin.

BARREL AVAILABLE IN 225 LITRES  
( TRANSPORT OR CHATEAU FINISH)  
ON ALLOCATION  
.....  
TIGHT GRAIN FRENCH OAK  
MATURATION 36 MONTHS  
SELECTION OAKSCAN® PURE TOAST



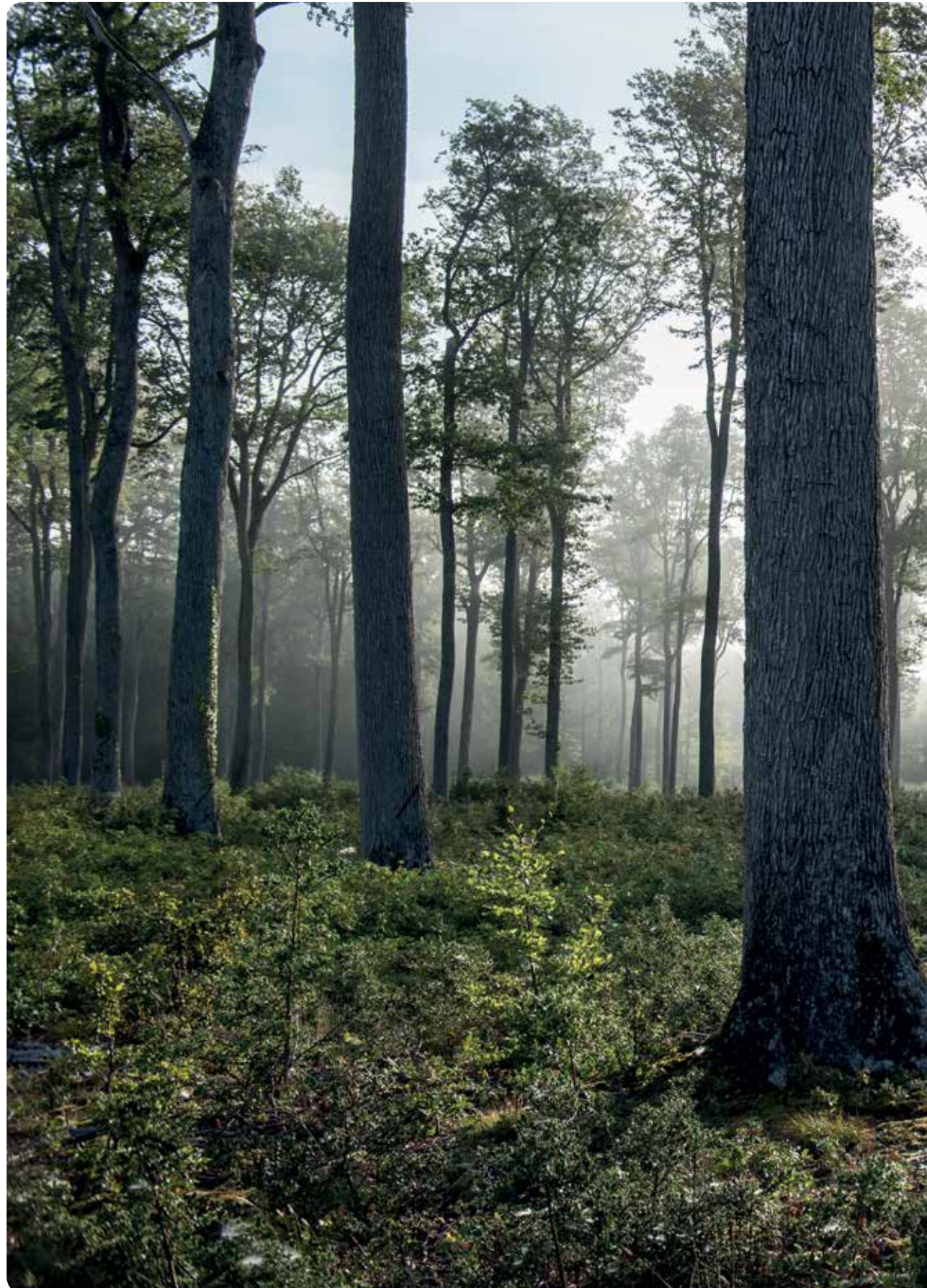

# The Bordeaux 225 litres

The 225L Bordeaux barrel is at the heart of the Tonnellerie Radoux range. It is meant for traditional aging.

## Transport 27mm

CAPACITY (L)	225
LENGTH OF STAVES (CM)	95
DIAMETER OF BILGE (CM)	68,5
DIAMETER AT HEAD (CM)	57,2
THICKNESS OF STAVES (MM)	25/27
GALVANISED HOOPS	6/8
CHESTNUT HOOPS	-
BUNG HOLE (MM)	50
PINE BAR	-
WEIGHT (KG)	47



## Transport 22mm

CAPACITY (L)	225
LENGTH OF STAVES (CM)	95
DIAMETER OF BILGE (CM)	67,5
DIAMETER AT HEAD (CM)	55,5
THICKNESS OF STAVES (MM)	20/22
GALVANISED HOOPS	6/8
CHESTNUT HOOPS	-
BUNG HOLE (MM)	50
PINE BAR	-
WEIGHT (KG)	41



## Château Ferrée

CAPACITY (L)	225
LENGTH OF STAVES (CM)	95
DIAMETER OF BILGE (CM)	69,7
DIAMETER AT HEAD (CM)	57,2
THICKNESS OF STAVES (MM)	20/22
GALVANISED HOOPS	6/8
CHESTNUT HOOPS	-
BUNG HOLE (MM)	50
PINE BAR	yes
WEIGHT (KG)	46



## Château Tradition

CAPACITY (L)	225
LENGTH OF STAVES (CM)	95
DIAMETER OF BILGE (CM)	69,7
DIAMETER AT HEAD (CM)	57,2
THICKNESS OF STAVES (MM)	20/22
GALVANISED HOOPS	6
CHESTNUT HOOPS	4
BUNG HOLE (MM)	50
PINE BAR	yes
WEIGHT (KG)	46



## 225L

	TRANSPORT 27MM	TRANSPORT 22MM	CHÂTEAU FERRÉE	CHÂTEAU TRADITION
EXTRA FINE X-BLEND	✓	-	-	✓
SUPER FINE BLEND	✓	✓	✓	✓
FRENCH OAK TIGHT GRAIN	OS ✓	OS ✓	OS ✓	OS ✓
FRENCH OAK ALLIANCE/MIXED (MEDIUM AND TIGHT GRAIN)	OS ✓	OS ✓	-	-
FRENCH OAK MEDIUM GRAIN	✓	-	-	-
AMERICAN OAK	✓	-	-	-
EASTERN EUROPEAN OAK	✓	-	-	-

The OakScan® process is systematically applied to all Radoux's French oak barrels. Tailored selections can also be offered on barrels marked OS



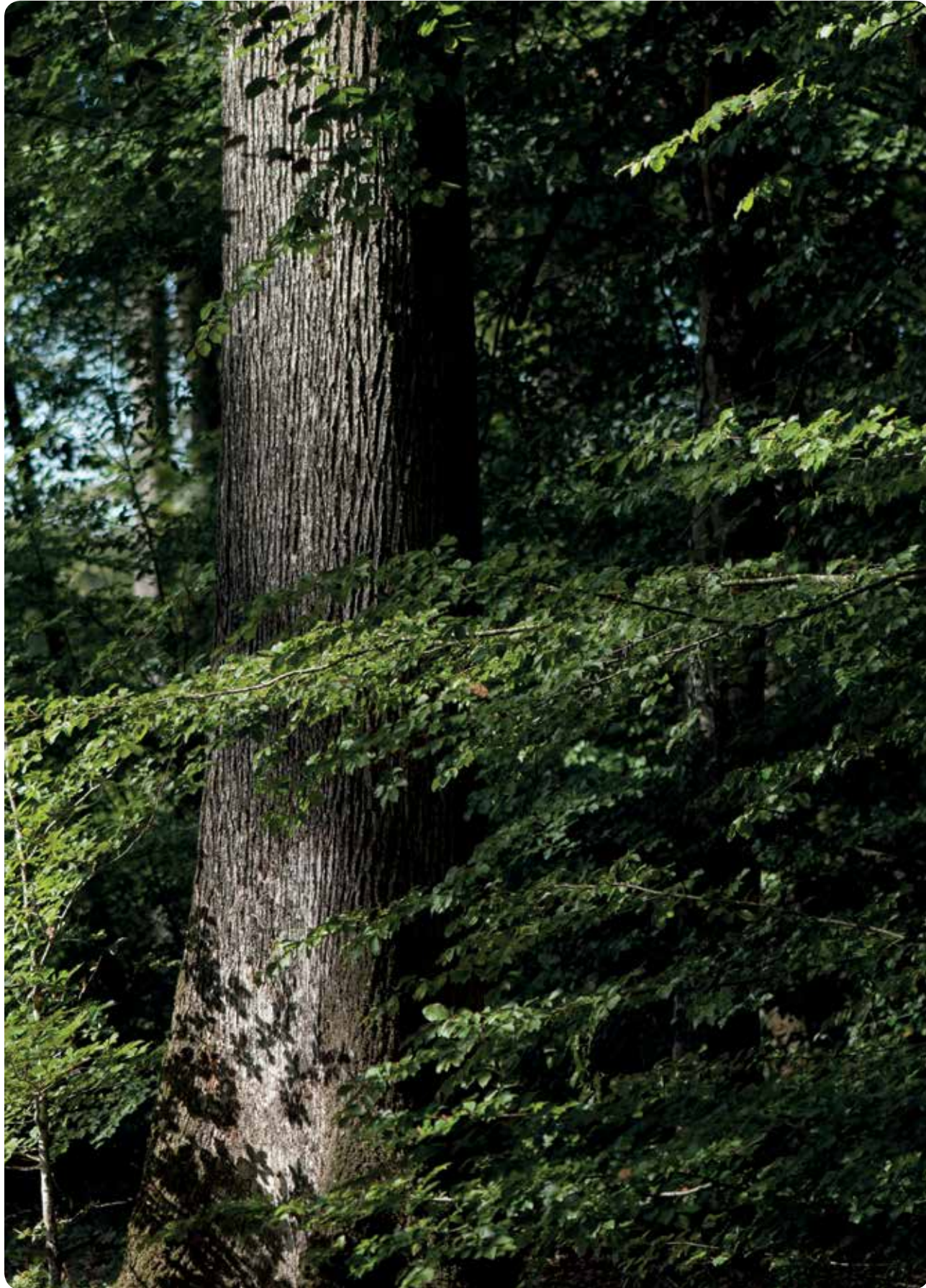

# The Burgundy 228 litres

This is the pride of Radoux, since the 1980s. The 228 litre Burgundy barrel is recommended for use in vinification and for aging Burgundy varieties (Pinot, Chardonnay ...) and fruity, delicate wines.

## Transport

CAPACITY (L)	228
LENGTH OF STAVES (CM)	88
DIAMETER OF BILGE (CM)	71,7
DIAMETER AT HEAD (CM)	60
THICKNESS OF STAVES (MM)	25/27
GALVANISED HOOPS	8
CHESTNUT HOOPS	-
BUNG HOLE (MM)	50
PINE BAR	-
WEIGHT (KG)	48



## Tradition

CAPACITY (L)	228
LENGTH OF STAVES (CM)	88
DIAMETER OF BILGE (CM)	71,7
DIAMETER AT HEAD (CM)	60
THICKNESS OF STAVES (MM)	25/27
GALVANISED HOOPS	6
CHESTNUT HOOPS	8
BUNG HOLE (MM)	50
PINE BAR	-
WEIGHT (KG)	48



## 228L

	TRANSPORT	TRADITION
<b>SUPER FINE BLEND</b>	✓	✓
<b>FRENCH OAK TIGHT GRAIN</b>	OS ✓	OS ✓
<b>FRENCH OAK ALLIANCE/MIXED (MEDIUM AND TIGHT GRAIN)</b>	OS ✓	OS ✓
<b>FRENCH OAK MEDIUM GRAIN</b>	✓	✓
<b>AMERICAN OAK</b>	✓	✓
<b>EASTERN EUROPEAN OAK</b>	✓	✓

The OakScan® process is systematically applied to all Radoux's French oak barrels.  
Tailored selections can also be offered on barrels marked OS



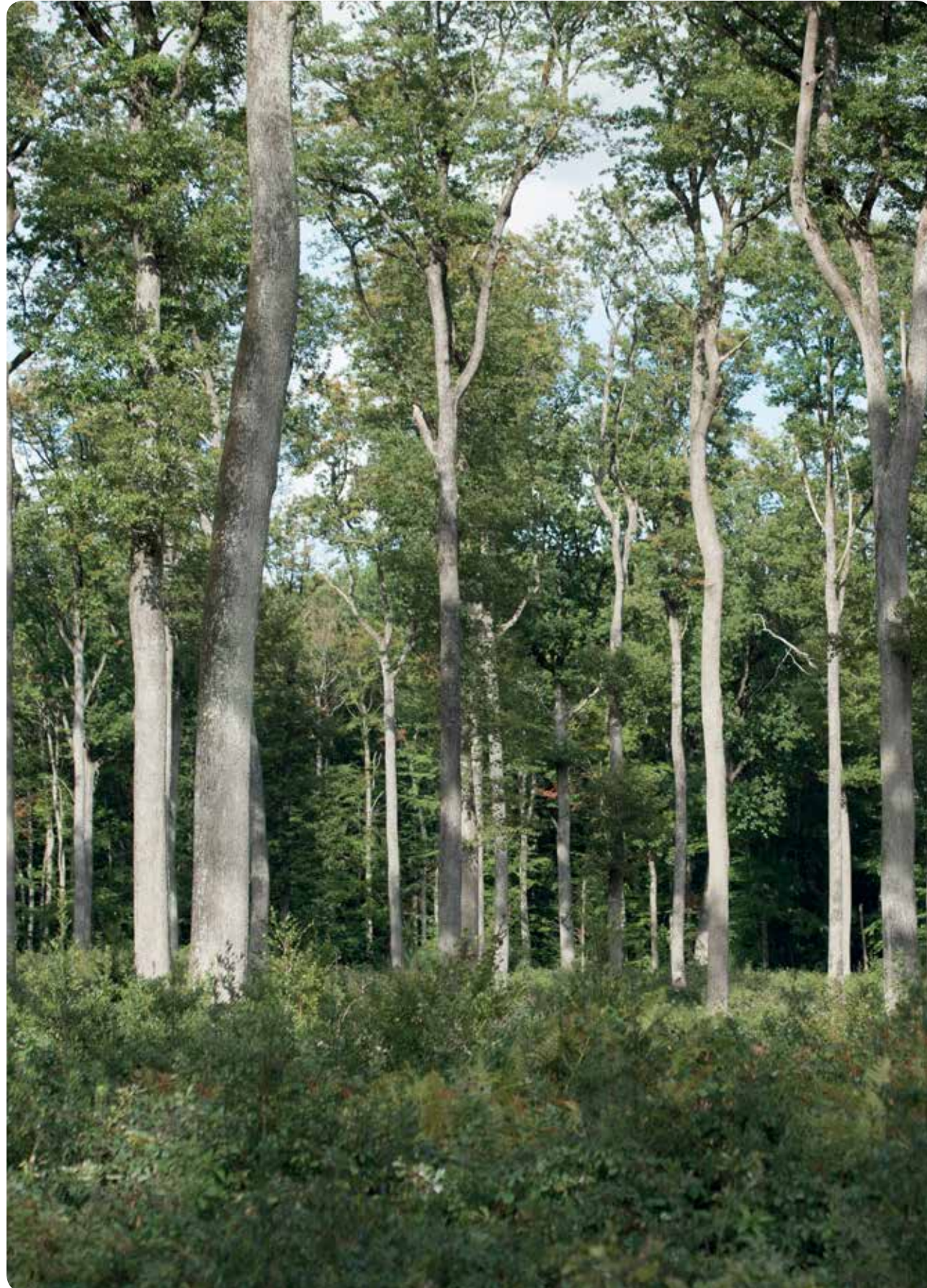

# Large barrels

While enabling the micro-oxygenation of the wine, our larger barrels (300L to 600L) bestow a more discreet oak character because of a smaller ratio of wood to wine. They are recommended for aging and can be adapted for vinification, allowing a permanent exchange between the pomace and the must.

## Transport 300L

CAPACITY (L)	300
LENGTH OF STAVES (CM)	100
DIAMETER OF BILGE (CM)	76,6
DIAMETER AT HEAD (CM)	64,5
THICKNESS OF STAVES (MM)	25/27
GALVANISED HOOPS	8
BUNG HOLE (MM)	50
WEIGHT (KG)	58



## Transport 350L

CAPACITY (L)	350
LENGTH OF STAVES (CM)	103
DIAMETER OF BILGE (CM)	81
DIAMETER AT HEAD (CM)	62
THICKNESS OF STAVES (MM)	25/27
GALVANISED HOOPS	8
BUNG HOLE (MM)	50
WEIGHT (KG)	60



## Transport 400L

CAPACITY (L)	400
LENGTH OF STAVES (CM)	105
DIAMETER OF BILGE (CM)	88
DIAMETER AT HEAD (CM)	72
THICKNESS OF STAVES (MM)	25/27
GALVANISED HOOPS	8
BUNG HOLE (MM)	50
WEIGHT (KG)	71



## Transport 500L

CAPACITY (L)	500
LENGTH OF STAVES (CM)	110
DIAMETER OF BILGE (CM)	91,7
DIAMETER AT HEAD (CM)	78,6
THICKNESS OF STAVES (MM)	25/27
GALVANISED HOOPS	8
BUNG HOLE (MM)	50
WEIGHT (KG)	82



## Demi-Muid 600L

CAPACITY (L)	600
LENGTH OF STAVES (CM)	115
DIAMETER OF BILGE (CM)	104
DIAMETER AT HEAD (CM)	91
THICKNESS OF STAVES (MM)	40/42
GALVANISED HOOPS	8
BUNG HOLE (MM)	50
WEIGHT (KG)	140



Barrel only available in classique medium or medium plus toast

	TRANSPORT 300L	TRANSPORT 350L	TRANSPORT 400L	TRANSPORT 500L	DEMI-MUID 600L
TIGHT TO MEDIUM GRAIN FRENCH OAK	OS ✓	✓	✓	✓	✓
AMERICAN OAK	✓	On request, limited quantities			—
EUROPEAN OAK	✓	On request, limited quantities			—

The OakScan® process is systematically applied to all Radoux's French oak barrels.

Tailored selections can also be offered on barrels marked OS





## Spirit barrels

**Because of our geographical situation in the heart of Cognac, we have acquired considerable expertise with regard to making spirit barrels and are proud to have the most famous Cognac houses amongst our clients. We are also developing our skills to create profiles suited to the aging of other brown spirits such as whisky or rum.**

For spirits, aging in oak barrels results in a harmonious exchange between wood, product and air. It is during this phase that a spirit gains color and aromas.

To make wide grain spirit barrels we use exclusively French oak, preferably from forests near the Limousin region. The quality of this oak is recognized as being ideal for spirits. The wood is denser, allowing for gradual oxidation and limiting evaporation.

Our tight grain oak comes from Central and Eastern France. Its contribution to color is less intense than wide grain oak, and it imparts an aromatic complexity made up of spices and lactones.



Thanks to our expertise in barrel making and strict selection of wood, the quality of your spirits can be fully expressed.



	TRANSPORT 225L	TRANSPORT 350L	TRANSPORT 400L
<b>TIGHT GRAIN FRENCH OAK</b>	✓	✓	✓
<b>WIDE GRAIN FRENCH OAK</b>	On request	✓	✓

The OakScan® process is systematically applied to all Radoux's French oak barrels.

Tailored selections can also be offered on barrels marked 



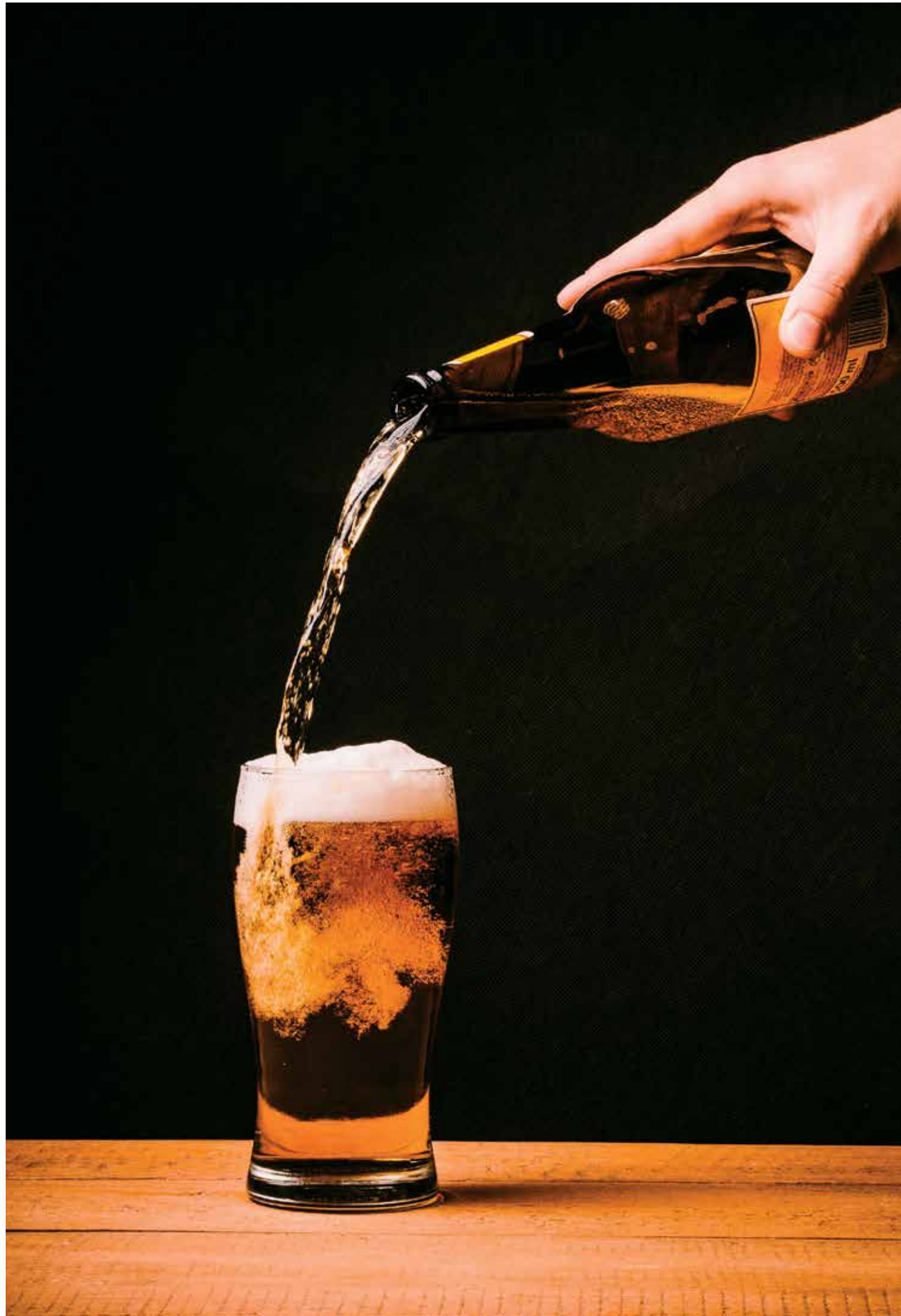

## Innovation and custom-made products, Radoux's DNA

**Since its creation, Radoux has made constant innovations, always anticipating the requirements and expectations of its customers. Our teams, with the support of experts, can offer solutions to the most diverse problems.**

**Our research has led us to understand and improve the interactions of wood with spirits such as tequila, ouzo, raki, gin, vodka... but also, more recently, with beer.**

Over the last few years we have seen the development of special beers, the creativity of this sector, and the return to traditional brewing and aging methods using oak barrels. Our exchanges and trials with brewers are growing and we notice that in a market where the need for innovation is constant, oak is an essential ingredient in differentiating and enhancing these beers which have such a strong identity.

Our R&D team has the support of experts and professionals such as the Institut Français de la Brasserie et de la Malterie (Qualtech) of Nancy to qualify and experiment with different oak profiles.

**We can offer brewers custom-made solutions to develop unique products. Together, we can create your formulas for beer with that special oak character.**





## Tables of recommendations

In the following tables, we have set up a classification of eight wine profiles in order to propose the most appropriate aging methods depending on the objectives you are seeking for your wines.

These profiles have been defined according to the wine varieties, the characteristics on the nose and palate of basic wines. Depending on the size of the container, the origin of the wood, the selection of grain and the type of toast, we recommend for each wine the intensity of aromas and structure and the optimum aging periods.

### Several technical strategies are suggested for these categories:

- Toasts at fairly low temperatures to obtain freshness
- Long or intense toasts to obtain more complex aromas and increase sweetness
- Medium toasts for a good balance aroma/volume
- Larger barrels to reduce the ratio wood/wine
- ...

This list is not exhaustive and can be adapted according to the style of wines required.

### Classification of wines

Profile of concentrated, balanced red wines	p 50/51
Profile of very mature red wines	p 52/53
Profile of varietal red wines	p 54/55
Profile of delicate red wines	p 56/57
Profile of delicate varietal white wines	p 58/59
Profile of mature, concentrated white wines	p 60/61
Profile of liqueur wines and natural sweet wines	p 62/63

<b>Spirits</b>	p 64/65
----------------	---------

# Profile of concentrated, balanced red wines

- **Varietals:** Merlot, Syrah, Malbec, Cabernet Sauvignon, Cabernet Franc, Tempranillo, Carignan, Marselan, Mourvèdre, Monastrell, Corvina, Montepulciano, Saperavi, Boğazkere.

- **Nose:** mature, but not over-ripe fruits with no vegetal notes. Aromas of dark fruits (cherry, blackberry, blueberry), spices (licorice, black olives), flowers (violet), mineral (shale, hot stones).

- **Palate:** concentrated and well balanced with a high tannin content, fatty, balanced acidity, tannins which are solid, mature, round, with no astringency, lingering, and sometimes sticky.

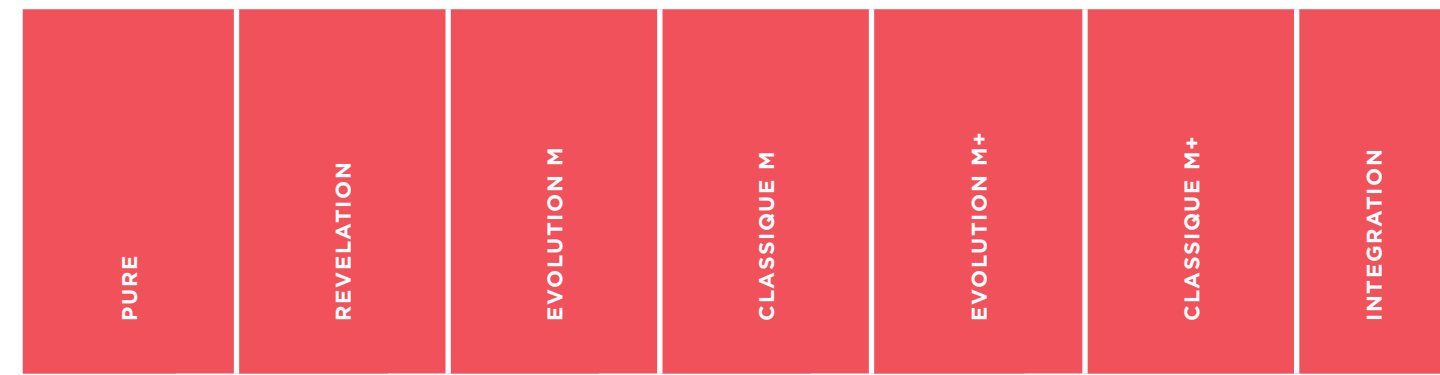

Oak Type	Oak Size	Polyphenolic Index Oakscan®	Aromatic Intensity	Structure	Aging period (months)	Not yet qualified	Not recommended	Not available	Recommended	PURE	REVELATION	EVOLUTION M	CLASSIQUE M	EVOLUTION M+	CLASSIQUE M+	INTEGRATION	
										Not yet qualified	Not recommended	Not available	Recommended				
French oak	225L / 228L		👉	👄	🕒												
	SUPER FINE BLEND EXTRA FINE X-BLEND	35 <sup>+/-5</sup>	👉	👄	🕒												
	OMEGA	30 <sup>+/-7</sup>	👉	👄	🕒												
	TIGHT GRAIN	40 <sup>+/-7</sup>	👉	👄	🕒												
	TIGHT GRAIN OAKSCAN 20	20 <sup>+/-4</sup>	👉	👄	🕒												
	ALLIANCE/MIXED (MEDIUM AND TIGHT GRAIN)	40 <sup>+/-10</sup>	👉	👄	🕒												
	MEDIUM GRAIN	50 <sup>+/-10</sup>	👉	👄	🕒												
300L	45 <sup>+/-10</sup>	👉	👄	🕒													
400L / 500L	45 <sup>+/-10</sup>	👉	👄	🕒													
American oak	225L / 228L		👉	👄	🕒												
	300L		👉	👄	🕒												
	400L / 500L		👉	👄	🕒												
European oak	225L / 228L	28 <sup>+/-7</sup>	👉	👄	🕒												
	300L	28 <sup>+/-7</sup>	👉	👄	🕒												
	400L / 500L	28 <sup>+/-7</sup>	👉	👄	🕒												

**LEGEND**

- 👉 Aromatic intensity
- 👄 Structure
- 🕒 6-18 Aging period (months)
- 🤔 Not yet qualified
- 😞 Not recommended
- 😘 Not available
- 👍 Recommended



# Profile of very mature red wines

**- Varietals :** Merlot, Grenache, Zinfandel (Primitivo), Touriga Nacional, Nero d'Avola, Tempranillo, Syrah, Saperavi.

**- Nose :** aromas of candied fruit (prune, fig, squashed strawberry, kirsch, dried fruits, fruits soaked in alcohol, fruit paste), spices (cocoa, eucalyptus), dry vegetal (tobacco, dried flower, straw), which can evolve slightly.

**- Palate :** moderately concentrated to concentrated, with an average to high tannic content, sweetness, low acidity. Very mature tannins which can evolve or slightly dry aftertaste.

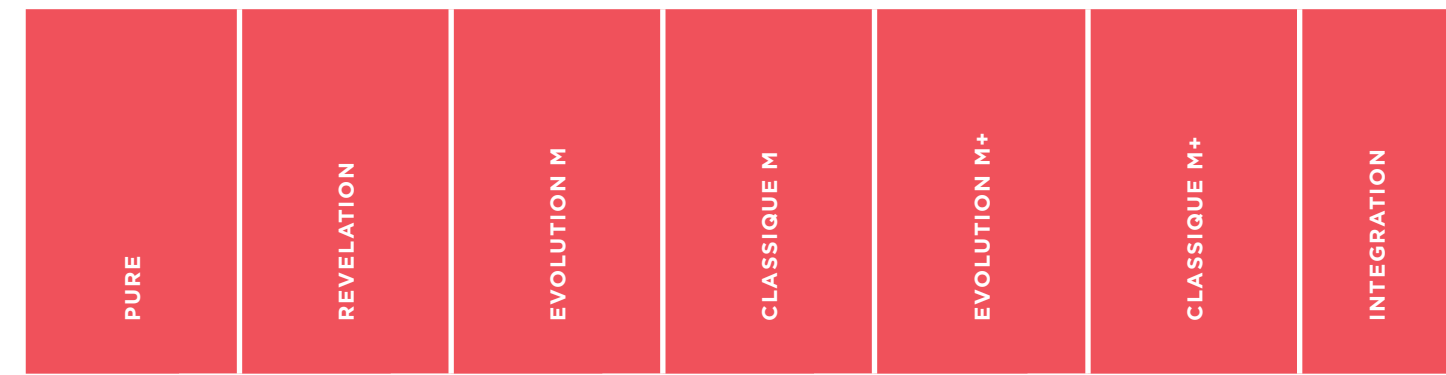

	Polyphenolic Index Oakscan®	Aromatic intensity	Structure	Aging period (months)	Not yet qualified	Not recommended	Not available	Recommended	PURE	REVELATION	EVOLUTION M	CLASSIQUE M	EVOLUTION M+	CLASSIQUE M+	INTEGRATION
French oak	225L / 228L														
	SUPER FINE BLEND EXTRA FINE X-BLEND	35 <sup>+/-5</sup>													
	OMEGA	30 <sup>+/-7</sup>													
	TIGHT GRAIN	40 <sup>+/-7</sup>													
	TIGHT GRAIN OAKSCAN 20	20 <sup>+/-4</sup>													
	ALLIANCE/MIXED (MEDIUM AND TIGHT GRAIN)	40 <sup>+/-10</sup>													
	MEDIUM GRAIN	50 <sup>+/-10</sup>													
American oak	300L	45 <sup>+/-10</sup>													
	400L / 500L	45 <sup>+/-10</sup>													
	225L / 228L														
European oak	300L														
	225L / 228L	28 <sup>+/-7</sup>													
	400L / 500L	28 <sup>+/-7</sup>													

**LEGEND**

- Aromatic intensity
- Structure
- Aging period (months)
- Not yet qualified
- Not recommended
- Not available
- Recommended



# Profile of red varietal wines

**- Varietals:** Cabernet Sauvignon, Tannat, Malbec, Petit Verdot, Carménère, Carignan, Lagrein, Öküzgözü.

**- Nose :** aromas of fresh fruits, moderate maturity with some vegetal notes. Fresh aromas (strawberry, redcurrant, raspberry, blackcurrant buds, tomato leaves, red pepper) spices (pepper, peppermint).

**- Palate :** moderately concentrated to concentrated with acidity. Reactive tannins, sometimes lacking roundness.

PURE REVELATION EVOLUTION M CLASSIQUE M EVOLUTION M+ CLASSIQUE M+ INTEGRATION

		Polyphenolic Index Oakscan®	
French oak	225L / 228L		
	SUPER FINE BLEND EXTRA FINE X-BLEND	35 <sup>+/-5</sup>	☹️👉
	OMEGA	30 <sup>+/-7</sup>	👉☹️
	TIGHT GRAIN	40 <sup>+/-7</sup>	👉☹️
	TIGHT GRAIN OAKSCAN 20	20 <sup>+/-4</sup>	☹️👉
	ALLIANCE/MIXED (MEDIUM AND TIGHT GRAIN)	40 <sup>+/-10</sup>	☹️👉
	MEDIUM GRAIN	50 <sup>+/-10</sup>	☹️👉
American oak	300L	45 <sup>+/-10</sup>	☹️👉
	400L / 500L	45 <sup>+/-10</sup>	☹️👉
	225L / 228L		☹️👉
European oak	300L		☹️👉
	400L / 500L		☹️👉
	225L / 228L	28 <sup>+/-7</sup>	☹️👉

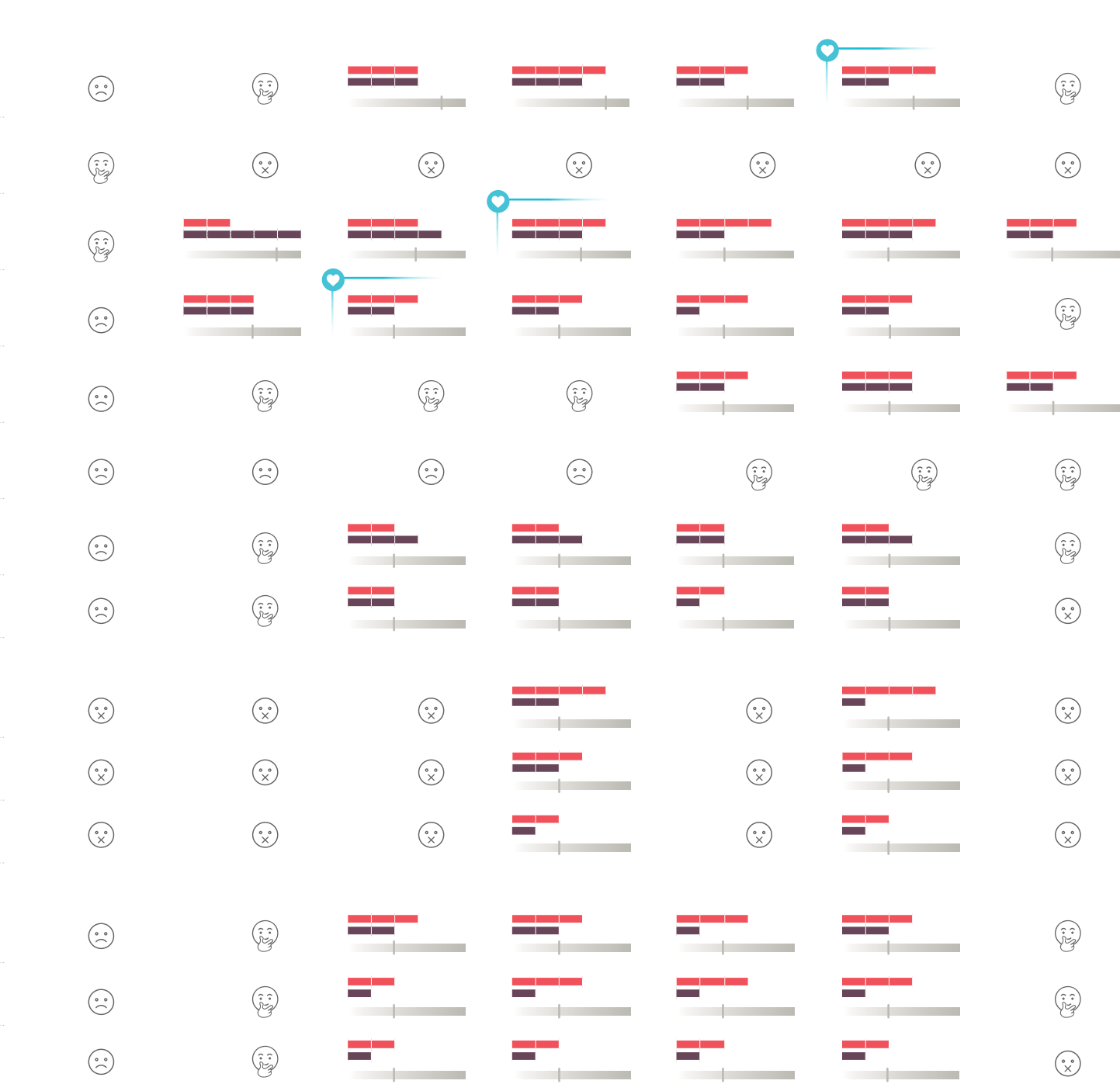

**LEGEND**

- 👉 Aromatic intensity
- ☹️ Structure
- 🕒 6 18 Aging period (months)
- 👉 Not yet qualified
- ☹️ Not recommended
- ☹️❌ Not available
- 😊❤️ Recommended



# Profile of delicate red wines

**- Varietals:** Pinot Noir, Grenache, Sangiovese, Nebbiolo, Cabernet Franc, Barbera, Gamay.

**- Nose:** Subtle, complex aromatic palette. Aromas : mature fruit (cherry, strawberry), fresh fruit (raspberry, redcurrant, blackcurrant) which can evolve, or with fermenting characteristics (tobacco, dry flowers, banana)

**- Palate:** moderately or only slightly concentrated, sometimes a little fragile and sensitive to taking on oak. Fine tannins which can be slightly dry depending on the level of maturity.

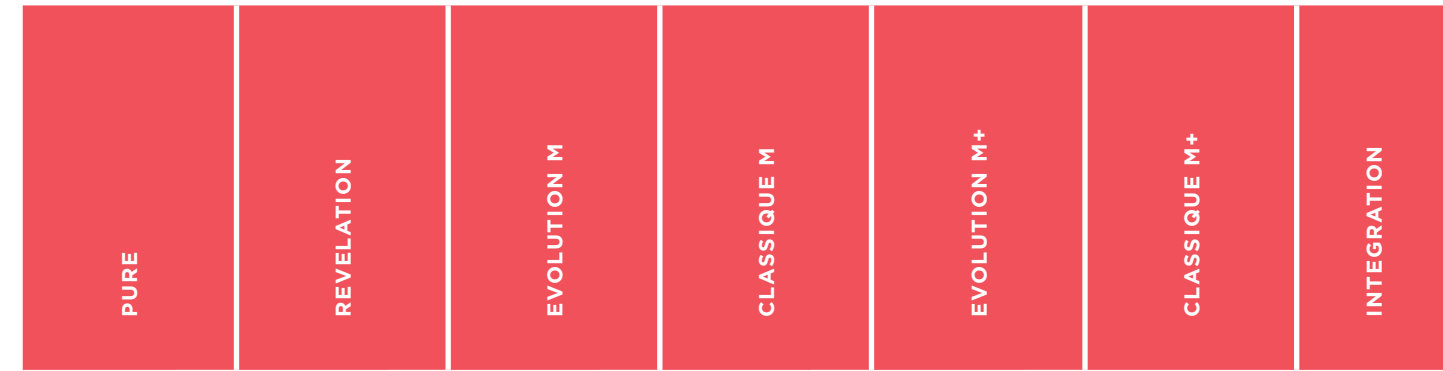

	Polyphenolic Index Oakscan®	Aromatic intensity	Structure	Aging period (months)	Wine Style													
					PURE	REVELATION	EVOLUTION M	CLASSIQUE M	EVOLUTION M+	CLASSIQUE M+	INTEGRATION							
French oak	225L / 228L																	
	SUPER FINE BLEND EXTRA FINE X-BLEND	35 <sup>+/-5</sup>	👉	🕒 6	🤔	🤔	👉	🤔	🤔	🤔	🤔	🤔	🤔	👉	🤔	👉	🤔	
	OMEGA	30 <sup>+/-7</sup>	👉	🕒 6	🤔	🤔	🤔	🤔	🤔	🤔	🤔	🤔	🤔	🤔	🤔	🤔	🤔	🤔
	TIGHT GRAIN	40 <sup>+/-7</sup>	👉	🕒 6	🤔	👉	👉	🤔	👉	👉	👉	👉	👉	👉	👉	👉	👉	👉
	TIGHT GRAIN OAKSCAN 20	20 <sup>+/-4</sup>	👉	🕒 6	🤔	👉	👉	🤔	👉	👉	👉	👉	👉	👉	👉	👉	👉	👉
	ALLIANCE/MIXED (MEDIUM AND TIGHT GRAIN)	40 <sup>+/-10</sup>	👉	🕒 6	🤔	👉	👉	🤔	👉	👉	👉	👉	👉	👉	👉	👉	👉	👉
	MEDIUM GRAIN	50 <sup>+/-10</sup>	👉	🕒 6	🤔	🤔	🤔	🤔	🤔	🤔	🤔	🤔	🤔	🤔	🤔	🤔	🤔	🤔
	300L	45 <sup>+/-10</sup>	👉	🕒 6	🤔	👉	👉	🤔	👉	👉	👉	👉	👉	👉	👉	👉	👉	👉
400L / 500L	45 <sup>+/-10</sup>	👉	🕒 6	🤔	👉	👉	🤔	👉	👉	👉	👉	👉	👉	👉	👉	👉	👉	
American oak	225L / 228L		👉	🕒 6	🤔	🤔	🤔	👉	🤔	👉	👉	👉	👉	👉	👉	👉	👉	
	300L		👉	🕒 6	🤔	🤔	🤔	👉	🤔	👉	👉	👉	👉	👉	👉	👉	👉	
	400L / 500L		👉	🕒 6	🤔	🤔	🤔	👉	🤔	👉	👉	👉	👉	👉	👉	👉	👉	
European oak	225L / 228L		👉	🕒 6	🤔	👉	👉	🤔	👉	👉	👉	👉	👉	👉	👉	👉	👉	
	300L		👉	🕒 6	🤔	👉	👉	🤔	👉	👉	👉	👉	👉	👉	👉	👉	👉	
	400L / 500L		👉	🕒 6	🤔	👉	👉	🤔	👉	👉	👉	👉	👉	👉	👉	👉	👉	

**LEGEND**

- 👉 Aromatic intensity
- 👉 Structure
- 🕒 6-18 Aging period (months)
- 🤔 Not yet qualified
- 🤔 Not recommended
- 🤔 Not available
- 👉 Recommended

# Profile of delicate white wines

**- Varietals:** Sauvignon Blanc, Sauvignon Gris, Riesling, Chenin, Trebbiano, Verdejo, Pinot Blanc, Pinot Gris, Vermentino, Viognier, Marsanne.

**- Nose:** delicate and fragile aromas, sensitive to oak. Depending on the varietal, wide aromatic palette: thiols (blackcurrant bud, blackcurrant leaves, tomato leaves, passion fruit), citrus fruit (lemon, grapefruit), white fruit (pear, white peach), floral (elderflower, white flowers), mineral (flint).

**- Palate:** low level of concentration, delicate, sometimes lively.

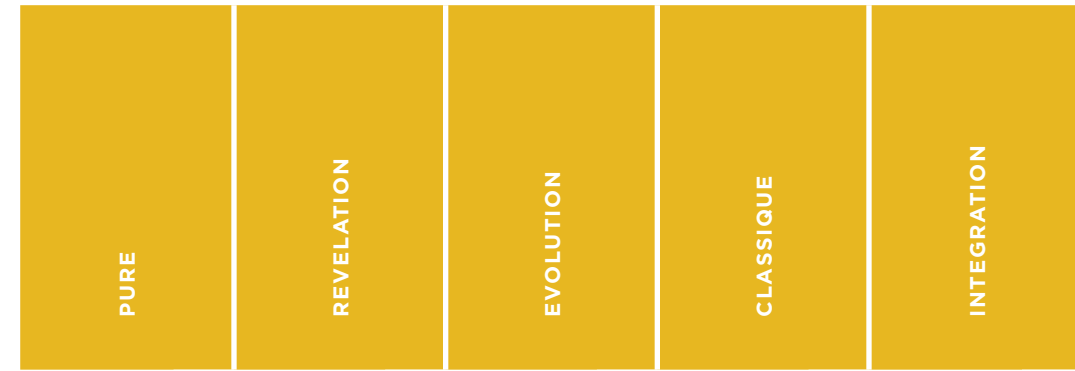

	Polyphenolic Index Oakscan®	Aromatic intensity	Structure	Aging period (months)	Not yet qualified	Not recommended	Not available	Recommended	PURE	REVELATION	EVOLUTION	CLASSIQUE	INTEGRATION
French oak	225L / 228L												
	SUPER FINE BLEND EXTRA FINE X-BLEND	35 <sup>+/-5</sup>											
	OMEGA	30 <sup>+/-7</sup>											
	TIGHT GRAIN	40 <sup>+/-7</sup>											
	ALLIANCE/MIXED (MEDIUM AND TIGHT GRAIN) OAKSCAN 30	30 <sup>+/-7</sup>											
	ALLIANCE/MIXED (MEDIUM AND TIGHT GRAIN) OAKSCAN 50	50 <sup>+/-7</sup>											
	MEDIUM GRAIN	50 <sup>+/-10</sup>											
	300L	45 <sup>+/-10</sup>											
400L / 500L	45 <sup>+/-10</sup>												
American oak	225L / 228L												
	300L												
	400L / 500L												
European oak	225L / 228L												
	300L												
	400L / 500L												

**LEGEND**

- Aromatic intensity
- Structure
- Aging period (months)
- Not yet qualified
- Not recommended
- Not available
- Recommended



# Profile of mature, concentrated white wines

- **Varietals:** Chardonnay, Sémillon, Muscadelle, Grenache Blanc, Gros Manseng, Roussanne, Viognier.
- **Nose:** aromas of mature fruits. Yellow fruit and exotic fruit (peach, apricot, mango, lychee, pineapple, melon), flowers (rose, acacia, jasmin, heady notes), dry fruit, nuts (hazelnuts, almonds).
- **Palate:** rich and concentrated, balanced acidity, fat and sweetness, opulence and persistence.

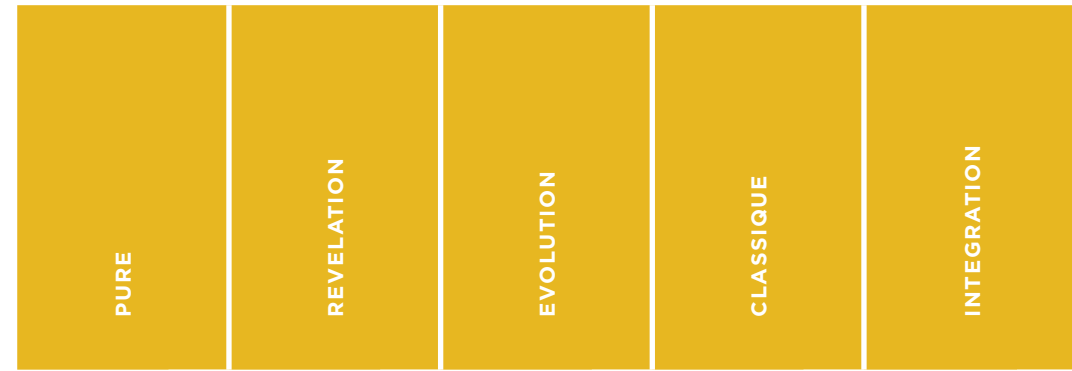

Oak Type	Cask Size	Polyphenolic Index Oakscan®	Aromatic Intensity	Structure	Aging period (months)	Not yet qualified	Not recommended	Not available	Recommended	PURE	REVELATION	EVOLUTION	CLASSIQUE	INTEGRATION
										Not yet qualified	Not recommended	Not available	Recommended	
French oak	225L / 228L													
	SUPER FINE BLEND EXTRA FINE X-BLEND	35 <sup>+/-5</sup>	High	High	6-12					Not yet qualified	Not available	Not yet qualified	Not yet qualified	Not yet qualified
	OMEGA	30 <sup>+/-7</sup>	Low	Low	6-12					Not available	Not available	Not available	Not available	Not available
	TIGHT GRAIN	40 <sup>+/-7</sup>	High	High	6-12					Not yet qualified	Not yet qualified	Not yet qualified	Not yet qualified	Not yet qualified
	ALLIANCE/MIXED (MEDIUM AND TIGHT GRAIN) OAKSCAN 30	30 <sup>+/-7</sup>	Low	Low	6-12					Not yet qualified	Not yet qualified	Not yet qualified	Not yet qualified	Not yet qualified
	ALLIANCE/MIXED (MEDIUM AND TIGHT GRAIN) OAKSCAN 50	50 <sup>+/-7</sup>	High	High	6-12					Not yet qualified	Not yet qualified	Not yet qualified	Not yet qualified	Not yet qualified
	MEDIUM GRAIN	50 <sup>+/-10</sup>	High	High	6-12					Not yet qualified	Not yet qualified	Not yet qualified	Not yet qualified	Not yet qualified
	300L	45 <sup>+/-10</sup>	High	High	6-12					Not yet qualified	Not yet qualified	Not yet qualified	Not yet qualified	Not yet qualified
400L / 500L	45 <sup>+/-10</sup>	High	High	6-12					Not yet qualified	Not yet qualified	Not yet qualified	Not yet qualified	Not yet qualified	
American oak	225L / 228L									Not available	Not available	Not available	Not available	Not available
	300L									Not available	Not available	Not available	Not available	Not available
	400L / 500L									Not available	Not available	Not available	Not available	Not available
European oak	225L / 228L	28 <sup>+/-7</sup>	Low	Low	6-12					Not yet qualified	Not yet qualified	Not yet qualified	Not yet qualified	Not yet qualified
	300L	28 <sup>+/-7</sup>	Low	Low	6-12					Not yet qualified	Not yet qualified	Not yet qualified	Not yet qualified	Not yet qualified
	400L / 500L	28 <sup>+/-7</sup>	Low	Low	6-12					Not yet qualified	Not yet qualified	Not yet qualified	Not yet qualified	Not yet qualified

**LEGEND**

- Aromatic intensity
- Structure
- Aging period (months)
- Not yet qualified
- Not recommended
- Not available
- Recommended

# Profile of liqueur wines and natural sweet wines

- **Varietals:** Sémillon, Petit Manseng, Chenin, Muscat, Grenache, Gewurztraminer, etc.
- **Nose:** aromas of candied fruit and complexity, all the palette of liqueur wines. Aromas : candied fruit, citrus fruit, dry fruit, exotic fruit, honey, flowers (lily, acacia) sometimes cocoa, truffle....
- **Palate:** concentrated and opulent, acidity more or less present depending on the varietal, fat and sweetness, sometimes alcoholic.

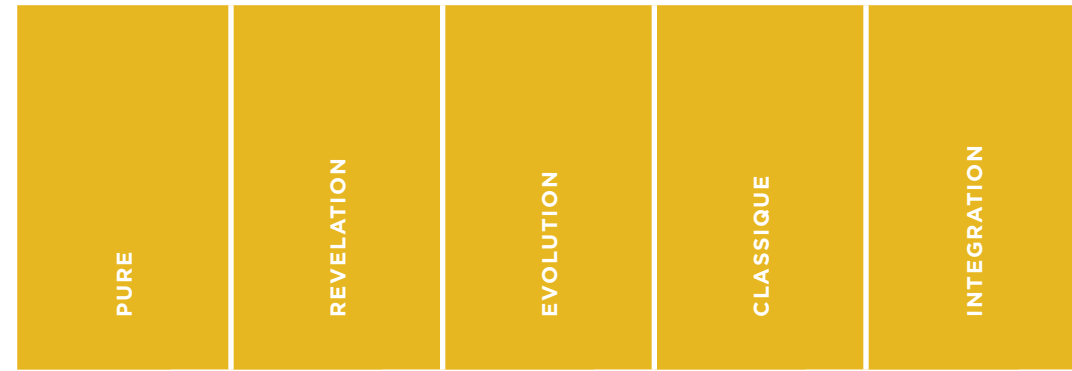

	Polyphenolic Index Oakscan®	Aromatic intensity	Structure	Aging period (months)	Not yet qualified	Not recommended	Not available	Recommended	PURE	REVELATION	EVOLUTION	CLASSIQUE	INTEGRATION
French oak	225L / 228L												
	SUPER FINE BLEND EXTRA FINE X-BLEND	35 <sup>+/-5</sup>	👉	🕒	🤔	🤔	🤔	🤔	👉	🤔	👉	🤔	🤔
	OMEGA	30 <sup>+/-7</sup>	👉	🕒	🤔	🤔	🤔	🤔	🤔	🤔	🤔	🤔	🤔
	TIGHT GRAIN	40 <sup>+/-7</sup>	👉	🕒	🤔	🤔	🤔	🤔	👉	🤔	👉	👉	🤔
	ALLIANCE/MIXED (MEDIUM AND TIGHT GRAIN) OAKSCAN 30	30 <sup>+/-7</sup>	👉	🕒	🤔	🤔	🤔	🤔	👉	🤔	👉	👉	🤔
	ALLIANCE/MIXED (MEDIUM AND TIGHT GRAIN) OAKSCAN 50	50 <sup>+/-7</sup>	👉	🕒	🤔	🤔	🤔	🤔	👉	👉	👉	👉	🤔
	MEDIUM GRAIN	50 <sup>+/-10</sup>	👉	🕒	🤔	🤔	🤔	🤔	👉	👉	👉	👉	🤔
	300L	45 <sup>+/-10</sup>	👉	🕒	🤔	🤔	🤔	🤔	👉	👉	👉	👉	🤔
400L / 500L	45 <sup>+/-10</sup>	👉	🕒	🤔	🤔	🤔	🤔	👉	👉	👉	👉	🤔	
American oak	225L / 228L												
	300L												
	400L / 500L												
European oak	225L / 228L	28 <sup>+/-7</sup>	👉	🕒	🤔	🤔	🤔	🤔	👉	🤔	👉	👉	🤔
	300L	28 <sup>+/-7</sup>	👉	🕒	🤔	🤔	🤔	🤔	👉	👉	👉	👉	🤔
	400L / 500L	28 <sup>+/-7</sup>	👉	🕒	🤔	🤔	🤔	🤔	👉	👉	👉	👉	🤔

**LEGEND**

- 👉 Aromatic intensity
- 👄 Structure
- 🕒 6 — 18 Aging period (months)
- 🤔 Not yet qualified
- 👎 Not recommended
- 👉 Not available
- 👉 Recommended



# Spirits

Wine spirits (Cognac, Armagnac, Brandy, Grappa), grain spirits (Whisky, Bourbon, Vodka), spirits made from plants (Rum, Tequila, Gin), anise spirits (Pastis, Ouzo, Raki)...

		Polyphenolic Index Oakscan®		PURE (Spirit)	MEDIUM (Spirit)	MEDIUM PLUS (Spirit)	HEAVY (Spirit)
French Oak	225L / 228L						
	TIGHT GRAIN	40 <sup>+/-7</sup>	↻				
	MEDIUM GRAIN	50 <sup>+/-10</sup>	↻				
	350L / 400L						
	TIGHT GRAIN	40 <sup>+/-10</sup>	↻				
	WIDE GRAIN	60 <sup>+/-10</sup>	↻				
American oak	225L / 228L		↻				
	300L / 400L		↻				

**LEGEND**

		Aromatic intensity
		Structure
		Not yet qualified
		Not recommended
		Not available

# Advice before use

## For immediate use

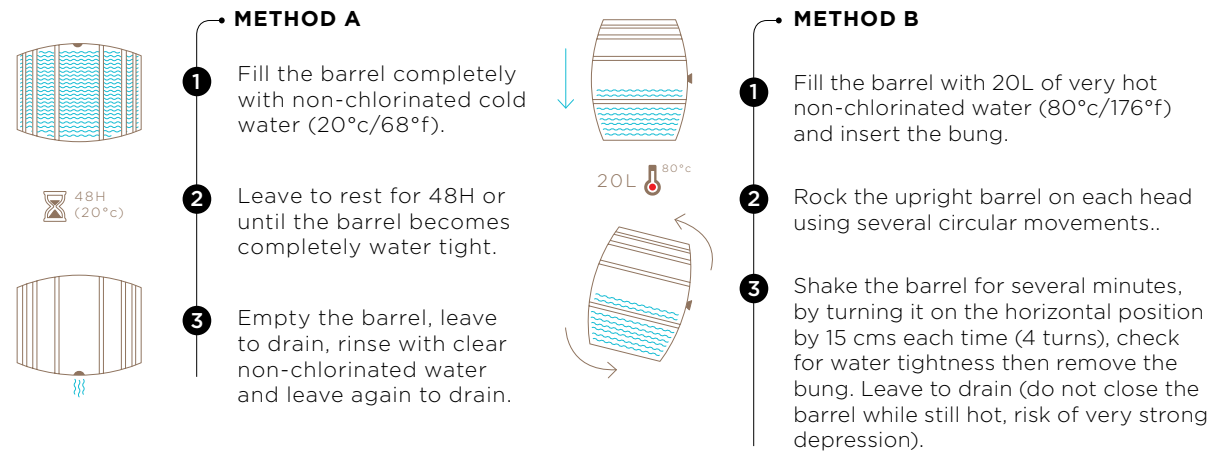

## If you will not be using your barrels for several weeks or months

- Keep in the original packaging.  
Store in place with following characteristics :
- Good hygrometry (75% - 80%)
  - No draughts
  - Low level of light
  - If necessary, cover the barrel with a tarpaulin (limit exposure to U.V.)

### IN CASE OF LEAKAGE

- Leave to drain, then leave to dry for an hour.
- Re-start method B.
- Empty the barrel, leave to drain and rinse with water.

**NB : if leaks re-appear, contact our Technical Department who will, if necessary, intervene on the spot**

We are working with a complex, natural product. We check our barrels with water and pressurization at two stages of production. We also advise that the barrels be prepped with water in the cellar prior to use. In spite of all this, barrels can present leakages when filled with the wine or spirit, which cannot be prevented.

# Options



BUNG	DIAMETER (BUNG HOLE)	ESQUIVE	POSITION	DIAMETER (BUNG HOLE)
Silicone bung	50	Planned	Center	35
Silicone bung collar	48	Traced	Right	38
Wooden bung	45	Pierced	Left	40
Glass bung	specific*	Burned	Center & Left Center & Right	specific*

HOOPING	VARNISH	BARS
Galvanized hoops	No varnish	Bar on front head*
Painted hoops	Varnish on chamfer	Bar on front and back head*
Chestnut hoops	Varnish on chamfer and bevelling	
Imitation chestnut plastic hoops		
Position of personalized hoops*		

MARKING	HEADS
Personalized laser marking (max 200x200mm)*	Bottom head delivered separately Positioning of bottom head

### LOADING CAPACITY (number of barrels)

	Type of vehicle				Type of container		
	20M3	19 T	TRAILER	TRUCK	20'	40'	40'HC
Bordeaux Transport 27mm 225L	30	80	152	240	67	138	156
Bordeaux Transport 22mm 225L	30	80	152	250	67	138	164
Bordeaux Château Ferré and Tradition 225L	30	76	148	235	67	138	152
Burgundy 228L	30	70	136	215	64	136	150
Transport 300L	25	56	108	119	51	108	114
Transport 350L	21	46	90	99	36	72	84
Transport 400L	21	46	90	99	36	72	72
Transport 500L	15	42	82	90	28	64	64
Transport 600L	6	13	26	29	20	44	44

\* subject to technical feasibility

### INTERPRETATION OF THE TRACEABILITY OF YOUR CODES

(OF = production order)

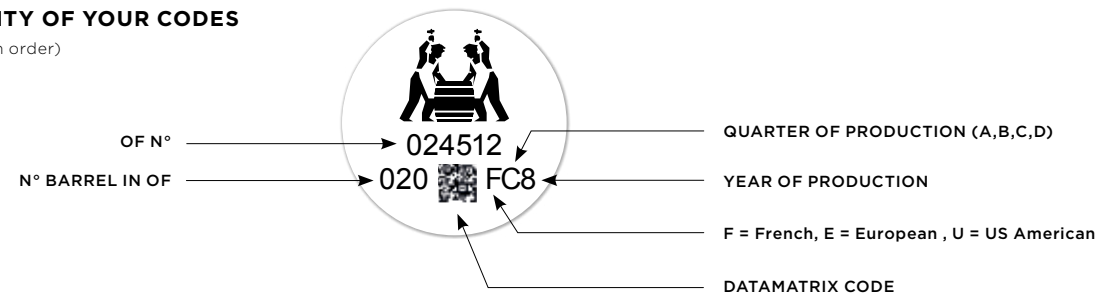





# Vats and Casks



**RADOUX**  
ARTISAN FOUDRIER  
DEPUIS 1947

## Radoux, Cask maker since 1947

Radoux is one of the rare barrel makers to have maintained and developed the ancient art of cask and vat making. Using the specific techniques of cabinet making and carpentry, this fine art belongs to the great tradition of craftsmanship.

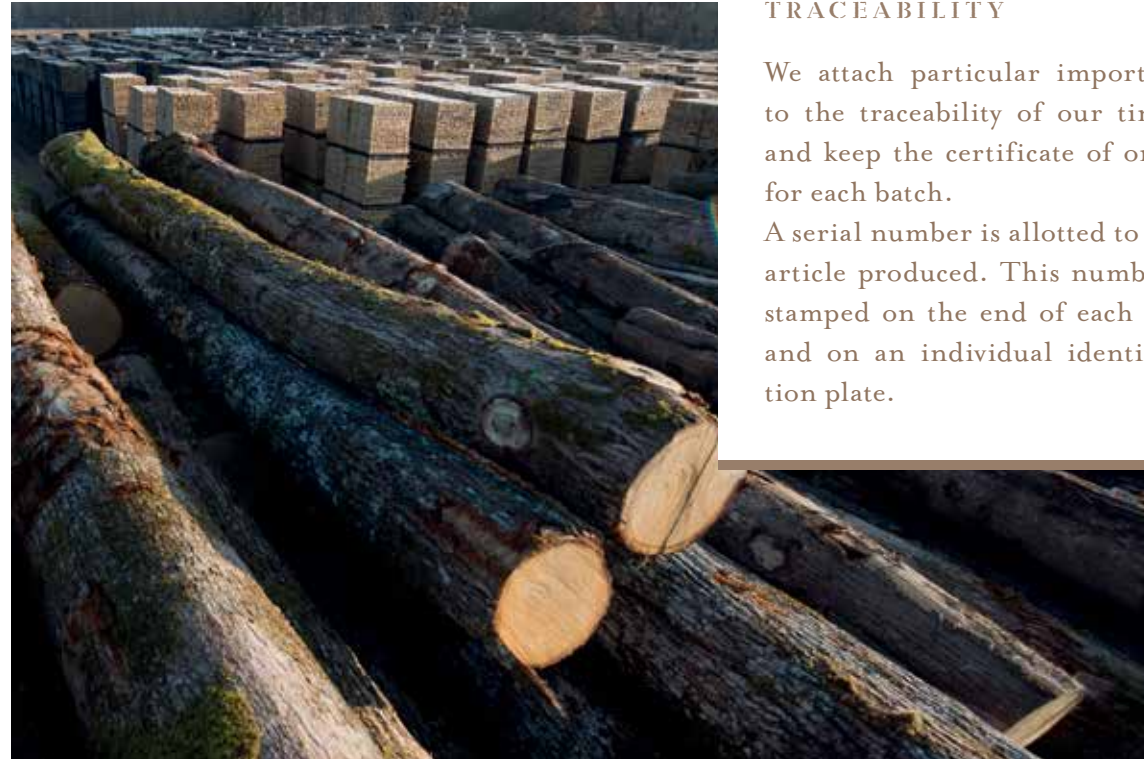

### TRACEABILITY

We attach particular importance to the traceability of our timber and keep the certificate of origin for each batch.

A serial number is allotted to each article produced. This number is stamped on the end of each stave and on an individual identification plate.

### Top quality oak of French origin

To make our vats and casks, we exclusively select barrel-grade French oak coming from the most prestigious forests (mainly from Central France). The wood is dried in the open air for a minimum of 3 years, ensuring optimal maturation.

Each piece of timber (trunk of the tree sawn into planks) must be perfectly straight, with a good size diameter and a medullary ray (or thread) perfectly parallel to the sides so as to guarantee maximum water tightness.

The wood is subject to a strict and methodical selection. Only the top-quality pieces, situated between the sapwood and the heart of the tree, and with good width, are chosen.

Following selection, samples of wood from each piece are sent to an independent laboratory to analyze the presence of any possible organochlorine derivatives. It is only upon confirmation that the analysis result is compliant that receipt of the wood is validated.

A second sample is taken on the finished product in accordance with our HACCP procedures.







## ELEGANCE AND TRADITION

Whether it be for vinification or for aging, oak vats and casks offer numerous benefits, and can be adapted according to your technical and oenological objectives.

- These prestigious containers **subtly enhance the wine with aromatics**, an unbeatable thermal inertia and a unique **micro-oxygenation**.
- Thanks to their truncated cone shape, the oak casks ensure an excellent **exchange between the must and the juice** during vinification, resulting in a better extraction.
- A **wide range of oenological** accessory options (thermoregulation, taps, doors...) helps complete the technical features.

The blond color of these prestigious containers adds beauty to the finest cellars, giving an unmistakable added value to the image of the cellars' brands.

## HAND CRAFTED, TAILOR-MADE PRODUCTS

**An expert for over 70 years in the art of making vats and casks for fermenting and aging wines and spirits, Radoux possesses an authentic savoir-faire combining tradition and innovation.**

Each vat or cask is unique, created by Radoux's research team and made mainly by hand by an expert team of master coopers.

The vats and casks are made in a dedicated workshop in Jonzac, where the cask makers use the utmost care while applying traditional ancestral techniques.

Each individual piece is prepared and assembled by hand.

The staves are tightened traditionally over a wood fire and held together with wooden pegs.

The toast lasts several hours and is carried out in the traditional method over a wood brazier. Toasting varies depending on the size and future use of the container.

The finishing of the vat or cask body and head is done by hand with great care to guarantee our customers receive an end product with perfect aesthetic appearance.

A food-safe, open pore varnish can then be applied to protect the wood from water.

The galvanized hoops, either unpainted or painted in the color of your choice, are then put into place.

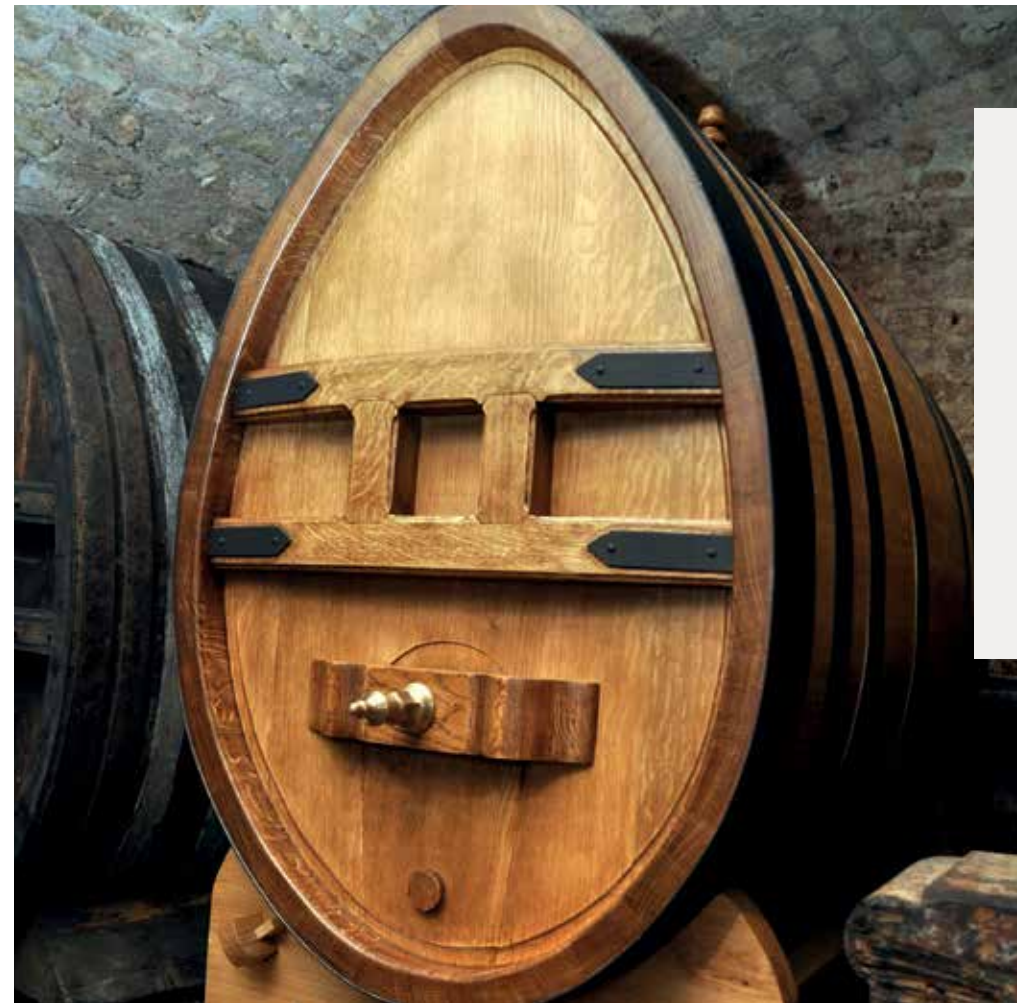

### A TIMELESS SAVOIR-FAIRE

Radoux was selected by the Historic Cellars of the Hospices de Strasbourg to replace the cask made specially to hold the oldest wine in the world (1472).

This exceptional work of art needed hundreds of hours to create and called upon the skills and virtuosity of Radoux's Meilleurs Ouvriers de France and Compagnons du Devoir. This technical challenge confirms Radoux's position as world leader for its expertise and reputation.

# Accompanying your project

Over the many years spent manufacturing casks, we have gained the experience and expertise which are essential in helping you succeed with your projects. From research to setting up your vats or casks, we pay careful attention to your requirements when it comes to planning and finalizing technical installations which are efficient, aesthetic and sustainable.

## 1 Diagnosis

To enable us to give you the best advice, we appraise the situation and define your project with you. Whether it be the installation of a vat or the overall design of a new vat cellar, we are here to guide you with the definition of your objectives while taking into account the technical and human constraints.

## 2 Tailor-made design

Truncated cone shape vats, round or oval casks of varied sizes are custom-made, depending on your oenological objectives (vinification or aging) or on your technical constraints. They are entirely customizable.

## 3 A wide range of accessories

We offer a full range of accessories to optimize the function of your wooden containers. All of our accessories are made of **316L** stainless steel and are made to order according to the size of the vats or casks. Moreover, they meet with the strictest safety & hygiene requirements.

## Our commitment

Our team of cask makers is at your disposal to guide you with the installation and assembly of your large capacity containers. Depending on the configuration of your cellars, your vats and casks can be delivered ready to be installed or dismantled and re-assembled on site.

We are here to advise you throughout the life of your products, from the initial set up, to post vinification cleaning and exterior maintenance.

## VATS (table of standard sizes adaptable upon request)

CAPACITY	HEIGHT (CM)	BOTTOM DIAMETER (CM)	TOP DIAMETER (CM)	LOADING IN CONTAINER 40' HC
10hl	120	133	118	✓
15hl	125	155	140	✓
20hl	140	166	150	✓
25hl	150	178	160	✓
30hl	170	182	162	✓
35hl	190	186	162	✓
40hl	200	193	168	✓
45hl	215	196	171	✓
50hl	220	203	177	✓
55hl	225	210	183	✓
60hl	230	216	188	✓
65hl	235	222	193	✓
70hl	240	228	198	✓
75hl	245	233	202	—
80hl	250	238	207	—
90hl	270	243	209	—
100hl	285	248	214	—
110hl	290	258	221	—
120hl	300	264	227	—
150hl	310	287	250	—
180hl	325	306	266	—
200hl	340	314	273	—

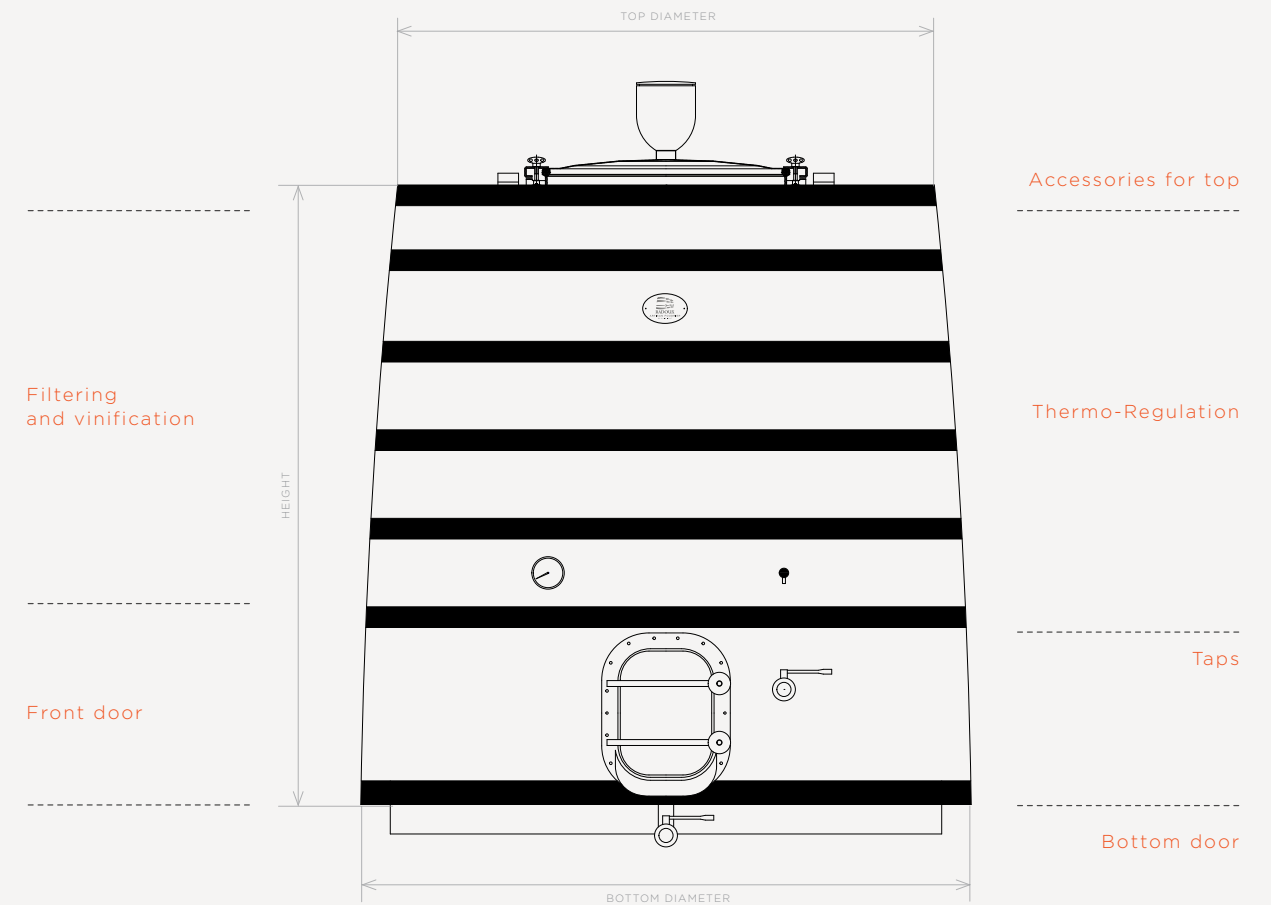



# CASKS

## ROUND CASK

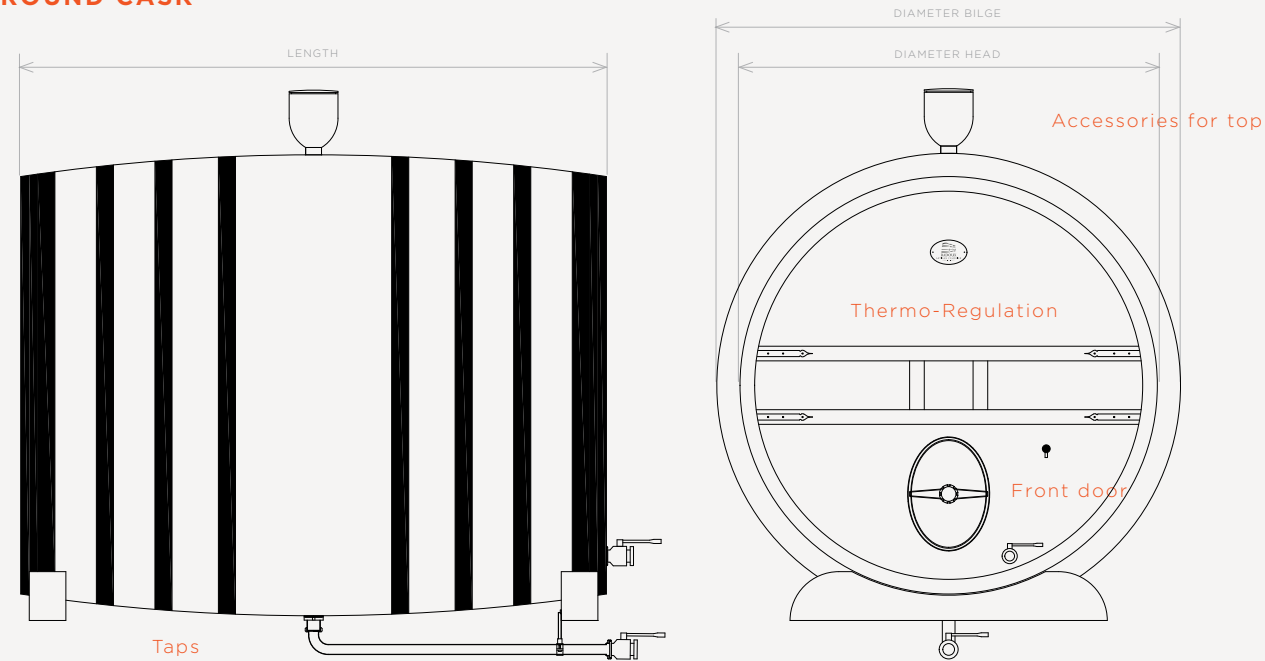

**ROUND** cask (table of standard sizes adaptable upon request)

CAPACITY	LENGTH (CM)	DIAM. BILGE (CM)	DIAM. HEAD (CM)	FRONT BARS	LOADING IN CONTAINER 40' HC
10hl	130	128	116	—	✓
15hl	140	148	134	—	✓
20hl	160	160	144	—	✓
25hl	170	173	155	single bar	✓
30hl	180	182	163	single bar	✓
35hl	190	190	171	single bar	✓
40hl	200	195	175	double bar	✓
45hl	205	204	183	double bar	✓
50hl	210	209	187	double bar	✓
55hl	215	214	191	double bar	✓
60hl	220	225	202	double bar	✓
65hl	225	225	205	double bar	✓
70hl	230	230	207	double bar	—
80HL	235	240	216	double bar	—

## OVAL CASK

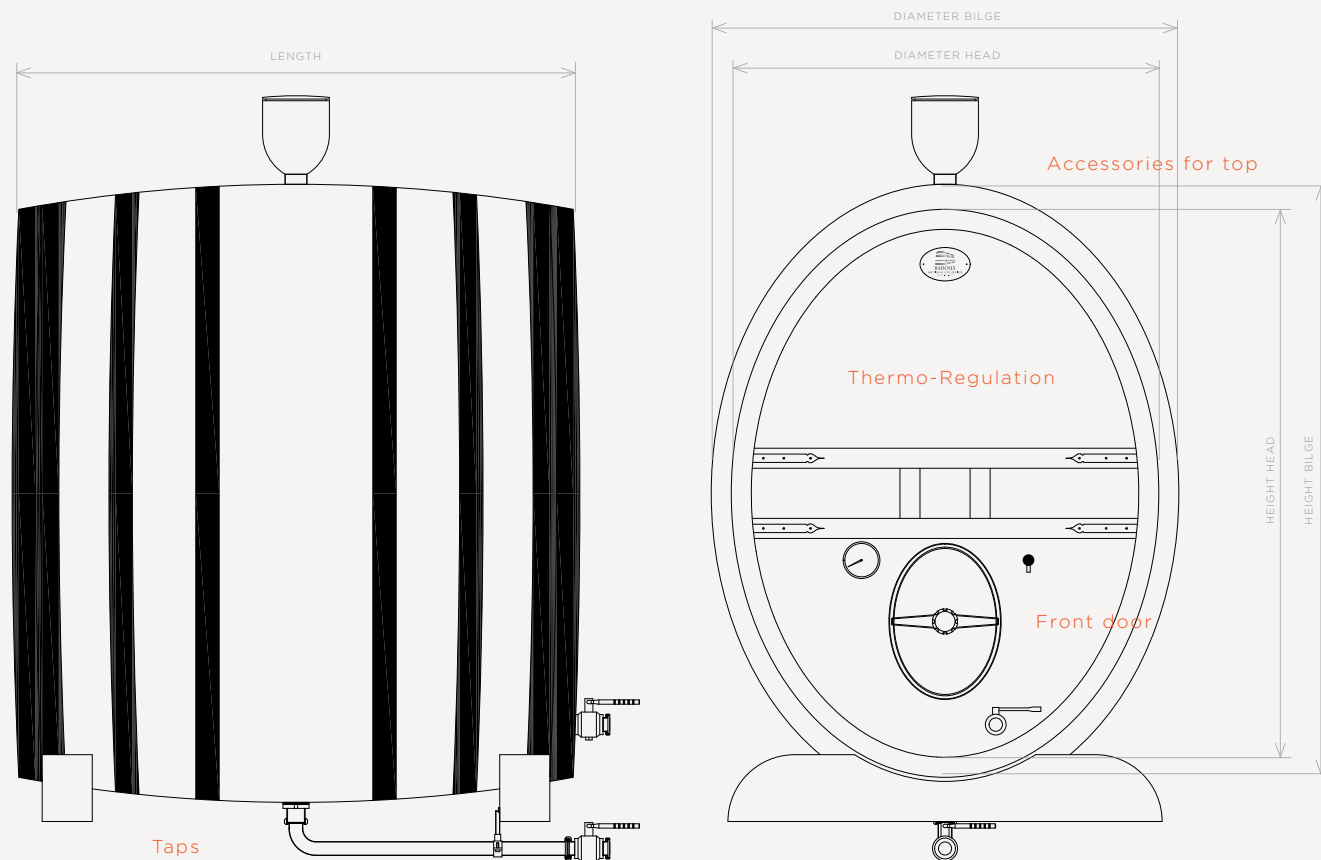

**OVAL** cask (table of standard sizes adaptable upon request)

CAPACITY	LENGTH (CM)	HEIGHT BILGE (CM)	WIDTH BILGE (CM)	HEIGHT HEAD (CM)	WIDTH (CM)	FRONT BARS	LOADING IN CONTAINER 40' HC
10hl	130	140	106	129	97.5	—	✓
15hl	140	160	121	147	111	—	✓
20hl	160	170	128.5	156	118	—	✓
25hl	170	185	140	170	128.5	single bar	✓
30hl	180	196	148	179	135.5	single bar	✓
35hl	190	205	155	187	141.5	single bar	✓
40hl	200	211.5	161	194	146.5	double bar	✓
45hl	205	222	168	202	153	double bar	✓
50hl	210	230	174	210	158.5	double bar	✓
55hl	215	237	179	216	163	double bar	✓
60hl	220	245	185	223	168.5	double bar	✓

**SEATING** (options)

Our products are delivered with oak chocks. These should then be placed on seating : wooden, concrete, stone... (not included). As an option, we can offer complete sets, in oak or stainless steel, to ease the movement and set up of the casks.

**CASKS**

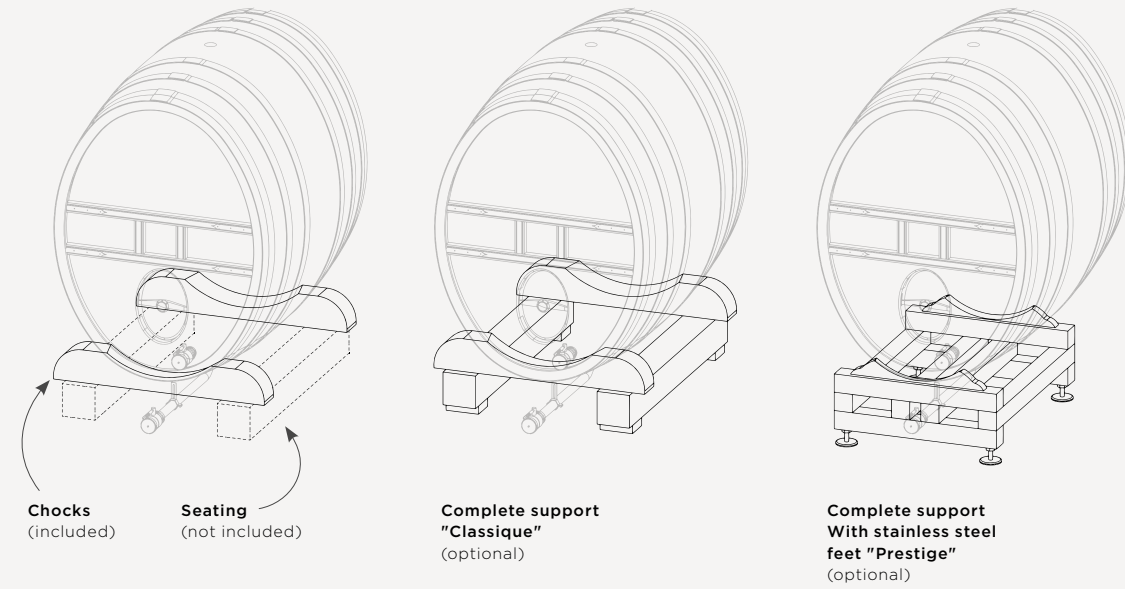

**VATS**

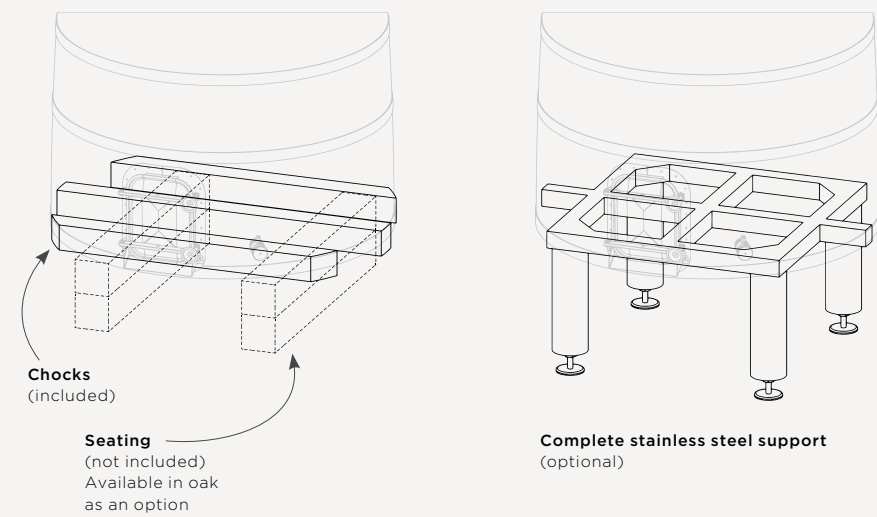





Our  
commitment

# Sustainable development

Just like the vine and the wine which span generations and only reach maturity after years of care, oak is a rare and precious raw material which evolves over time. It is therefore only natural that Radoux committed itself many years ago to supporting sustainable development.

This approach is three dimensional:

## Environmental

We guarantee the traceability of the wood from the forest to the finished product. Our traceability system (certified **ISO 9001** and recognized by **Bureau Veritas**) guarantees the French origin of the Radoux barrels "Chêne Français Origine Contrôlée". We pay close attention to the preservation of our oak wood resources. Our French oak **PEFC** certification recognizes that we respect environmental, social and economic functions of the forest.

Our cooperage, stave mill and site for the manufacture of wood for oenology are subject to the Classified installation for the Protection of the Environment. They undergo strict controls with regard to emissions (water and air) and safety regulations (fire detection and intervention) in order to preserve the environment. We are also careful about the visual and noise integration (acoustic ceiling, sound insulation walls, machine cladding...) in our installations.

## Economic

We pay special attention to reducing our consumption of raw material by having our own wood purchasers carry out a strict selection of barrel grade timber in the forest.

Our optimization software for the transformation of logs associated with the laser machining tools allows us to extract top quality raw material. The entire transformation process is monitored by computer with wood performance indicators.

The majority of by-products resulting from our production are recycled. The bark, sawdust, sapwood etc. are used to produce energy or are incorporated into the production of paper or minerals. Dry oak wood shavings are used in our braziers to heat the barrels.

Any barrel grade oak presenting defects impacting the aesthetic or mechanic quality of the future barrel is used to manufacture chips (after maturation in our wood yard, crushing and toasting in our own installations, thus limiting transportation and the resulting carbon footprint).

## Social

We are concerned about the health and safety of our employees and are therefore constantly improving our equipment and working conditions (especially noise, dust and ergonomics). This is reflected in our Unique Document for the Evaluation of Risks and in the periodic meetings of our Committee of Hygiene, Safety and Working Conditions.

Our Management Chart encourages and favors trust, initiative, training and listening to our staff in the Radoux family spirit which has existed since 1947. Annual appraisals help maintain and develop the competence and expertise of our staff, which are essential in light of the quality requirements in manufacturing our premium products. We adhere to labor laws within our own teams and those overseas.



### PEFC Certification

Respect of environmental, social and economic functions of the forest.

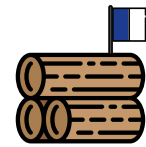

### Traceability

Certificate N° 059/RE of recognition by Bureau Veritas of French origin of Radoux barrels "Chêne Français Origine Contrôlée" (mention «Origine Contrôlée» on invoice).



### Recycling

The majority of by products from our production are recycled



### Offices & Workshops

We are constantly improving our equipment and working conditions.



### Training

Developing competence and expertise of our staff.

## Spirit of partnership

Customer satisfaction is the foundation of our company culture. We are constantly attentive to our customers' needs, and therefore not only do we seek excellence for our products through our integrated R&D (certified ISO), we also work in partnership with international universities and wine research centers.

With long term relationships in mind, we ensure our customers are completely satisfied with our services, by qualifying and controlling our raw material, monitoring the production, and dealing with the feedback received from our sales team/oenologists and our team providing technical support to customers.

Lastly, as the world of wines and spirits reflects a certain « art de vivre », we also support projects such as the Cité du Vin in Bordeaux.



## Quality references

The **ISO 9001** certification validated our **Quality Management System** in 1995. This engagement to quality, anchored in the culture of the company since its creation, currently concerns the following areas:

- Quality of conception, manufacture and sales of 225 to 500 liter barrels
- International technical support to customers
- Control of critical points of food safety during production
- Safety of staff and equipment
- Reduction of the impact of our activity on the environment
- Control of receipt and maturation cycle of raw staves

### Respect of regulations

Radoux ensures the sanitary and organoleptic safety of its barrels through:

- The use of the HACCP method in accordance with the recommendations of the Fédération des Tonneliers de France
- Control programs of the raw material, consumables, water and atmosphere (TCA, TBA, PCP... )
- Control programs of maturation time, grain, temperature of the toast
- Identification and strict traceability at every stage of production



## Our team

**Customer satisfaction is the foundation of our company culture. It is what motivates our high-quality standards and our strategy of research and innovation.**

Radoux's first commitment is to deliver a product which fully complies with our customers' requirements, and to do everything possible to improve customer satisfaction. Our constant aim is to plan, develop, control and improve every aspect of our production facilities and our working methods.

An oenologist and sales person are permanently at your disposal. They are professionals in wine tasting, and can advise you on the type of barrel which will meet with your requirements. They check on conformity of the products on delivery, and come to your cellars regularly to monitor the aging process and at the end of this process assess with you whether any adjustments should be made for the next vintage. Radoux takes its expertise into your cellars with personalized tasting trials carried out by our team of specialists based in all the wine regions worldwide. An after-sales service is also available to offer advice on how to use and maintain your barrels.

Radoux is a fully committed, trusted, long term partner of your Cellar Masters and oenologists. The "best" barrel is the one that will allow you to obtain exactly the type of wine you are seeking to produce.









**Tonnellerie RADOUX**

10, AVENUE FAIDHERBE  
CS 30113  
17503 JONZAC CEDEX  
FRANCE  
Tel : +33 (0) 5 46 48 00 65  
Fax : +33 (0) 5 46 48 47 77  
Email : rx@radoux.fr

**WWW.RADOUX.FR**